

Digital Broadcast Multi-processing Software Platform



VILLAGEFLOW

“VILLAGEFLOW (TM)” is the ultimate software platform for generating, operating, processing and monitoring Digital Broadcast TV (Transport Stream) signals. VILLAGEFLOW is optimized for real-time and continuous 24H/7D operation and supports a wide range of input/output adapters (DekTec and other third party vendors).

Basically, you can build the most inexpensive, flexible and highly functional broadcast facilities, while enabling various experimental broadcast signals and challenging services. VILLAGEFLOW is compliant with world standards such as DVB, ISDB-T, DTMB, ATSC, DVB-S/S2, DVB-T/T2, DVB-C/C2, including modules for RF modulation and demodulation, data broadcasting, EPG generation, sub-titling, detailed monitoring and supports for all video standards ranging from mobile TV to High-Definition and even higher (ex:4K,..) schemes.

VILLAGEFLOW Architecture

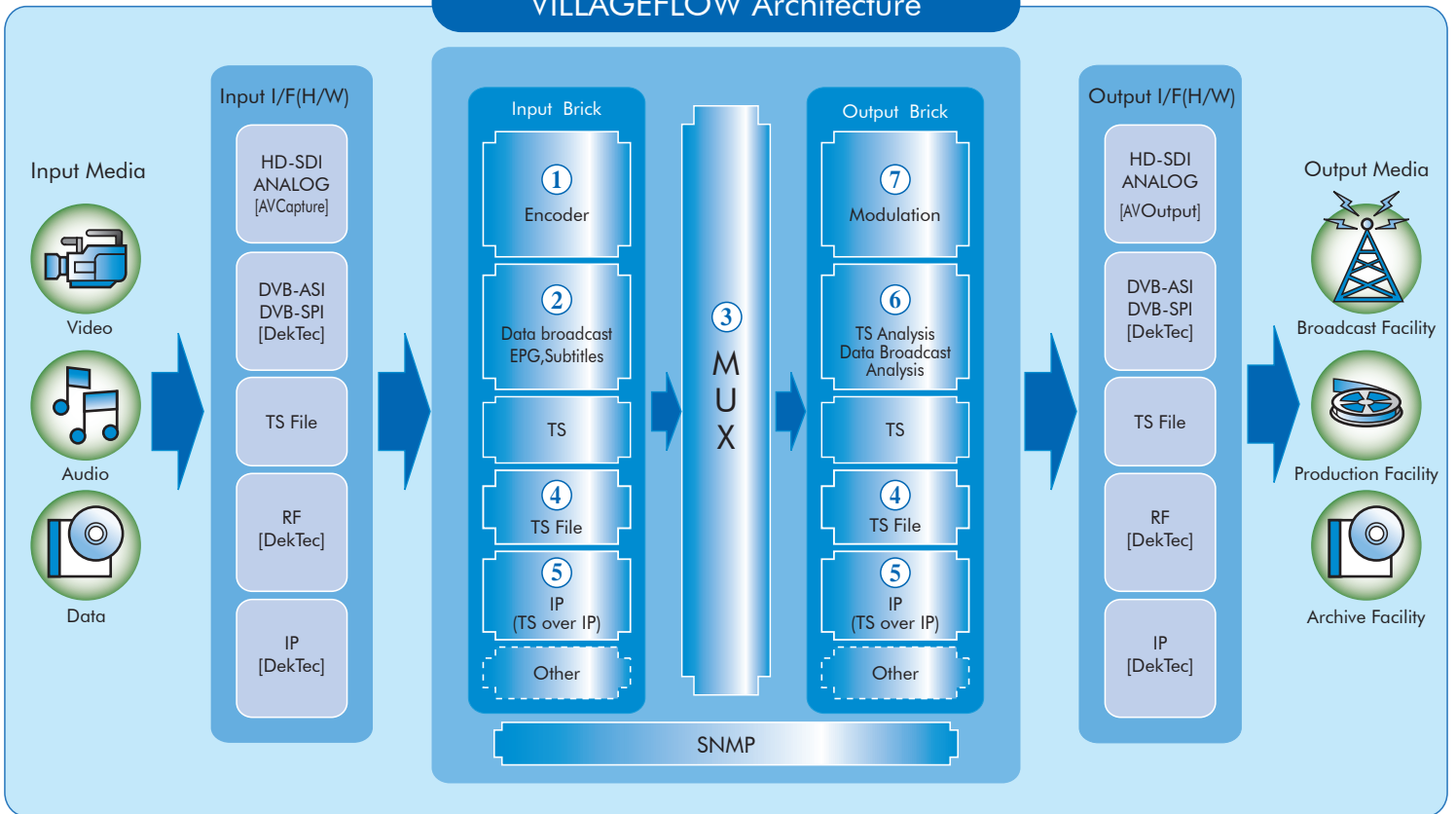

Functions

The following TS processing modules are available in VILLAGEFLOW software. You can build systems suitable for your purpose by combining these modules :

1 Real time encoder

- H.264 (S/W)
H.264-HD, SD, Mobile TV (1seg,iPhone,..)
- H.264 High-End Encoding
High-quality encoder (S/W)
- MPEG2 (S/W, H/W)
MPEG2-HD, SD
- MPEG2 High-End
High-End MPEG2 encoder (H/W)
- Audio (S/W)
MPEG1-L2, AAC etc
- PC screen capture
- Compliant with AVI file and other A/V file input

2 EPG, Sub-Titling, Data broadcast

- EPG
 - Automatic generation and updating EPG data from standard XML files
- Data broadcasting (ex: BCML, etc..)
 - Capable of transmitting multiple ES
 - Module updates
 - Event messages
- Subtitles
 - Transmit subtitles synchronously with video (for fixed reception TV and Mobile TV)

3 Multiplexer

- Up to 16x TS Input re-multiplex
- PID filtering and remapping
 - Specify PID and range of PID
- Service Management
 - Time stamp adjustment
 - PCR re-stamp
- PSI/SI generation and transmission
 - PAT, CAT, PMT, NIT, EIT, SDT, TDT/TOT, BIT, and much more
- TS distributed output available
- Real-time TMCC encoding
- Real-time BS satellite signal splitting

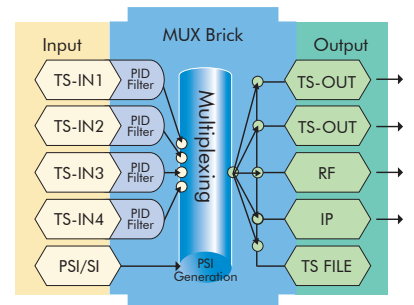

4 TS file

- TS file input
 - Scheduled control for playing of TS files
 - Loop and replay control enabled for single file and multiple file list
 - Time stamp adjustment (PCR, PTS/DTS, TOT)
- TS file output
 - Saved as TS file
 - File cut according to user settings (Ex: every x minutes or y MByte)

5 TS over IP

- IP specification
 - Protocol: UDP (Multicast and Unicast), TCP (Unicast) and RTP (RTP only available with DekTec adapters)
 - Bi-Dimensional (ProMPEG) FEC (with DekTec adapters)
 - Setting items: Specify IP address and port number
- ※ Caution in regards with IP in/out usage
 - Prepare proper IP network and connections.
 - Prepare sufficient bandwidth for your purpose.
 - We can advise several choices and adapters according to your specific needs.

6 TS analysis and monitoring

- TS analysis
 - TS packet analysis
 - TS rate (per Service, per PID)
 - PCR analysis
 - PSI/SI (including TOT) analysis
 - Data broadcast analysis
- TS monitoring
 - Fully compliant with ETR-101290

7 Modulation and Demodulation

- Modulation
 - OFDM (ISDB-T, DVB-T, ATSC, DTMB, CMMB, CMMA, DVB-T2) and QAM (A/B/C) modulation detailed control
 - Frequency and output level control
- Demodulation
 - Simple channel selection through channel number or frequency setting
 - Optional RF analysis
- Ask for details about
 - DVB-T2/C2
 - DVB-H/SH
 - ATSC-MH
 - ISDB-T, DTMB, CMMA, etc

Features

Thanks to VILLAGEFLOW, it is now possible to achieve unequalled levels of flexibility, integration, and cost-performances so far impossible with traditional dedicated appliances.

1

Flexible software modules for any digital TV functions and processes

- ◆ Former standard hardware functions are now replaced by VILLAGEFLOW software
- ◆ Maximum of flexibility and usage scope matching your broadcast needs
- ◆ Inter-operability with a maximum of interface and hardware
- ◆ High-end and optimized processing provided for real-time operation

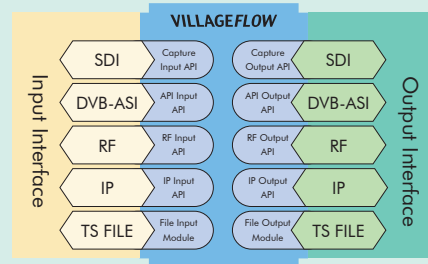

2

Cost and space savings for your broadcasting system

- ◆ One PC or server can replace the functions of a full HE rack
- ◆ Inexpensive implementation for customized sub-systems, for your back-up or main transmission system
- ◆ Standard interfacing (ASI, TS over IP, SPI, etc..) for easy connection to your other broadcast equipments

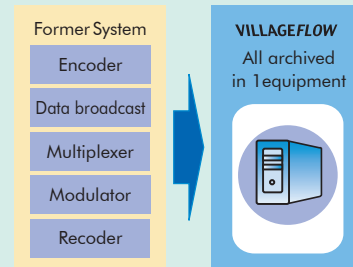

3

Easiness of integration

- ◆ Integration and compatibility for your HE appliances and systems
- ◆ Can be integrated with your S/W or H/W platform, and customized for your need
- ◆ Fit with advanced remote control Web User Interface (VFGUI), SNMP support, XML file base control with FTP

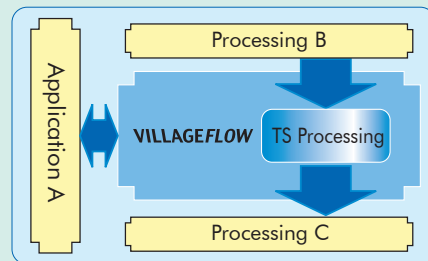

4

Open and complete SDK for advanced development and customizations

- ◆ GUI and top-level application development platform (including sample codes with tools for graph and real-time graphical reports, status display (ex: LED) and detailed controls of each functions.)
- ◆ TS processing "Brick" module development platform (input, process and output sample codes)
- ◆ Third Party I/F and library imports (feel free to ask details or communicate us your specific requirements)
- ◆ Flexible customization and open mind for new projects is our common policy

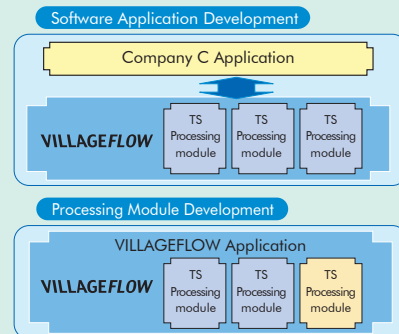

Structure

The VILLAGEFLOW flexibility is possible thanks to its layered and modular architecture.

Layer structure

Application layer

- GUI application
- Console application, Services
- Web application
- Customized application

TS processing function/module layer (Brick)

- Bricks are unique modules for each type of digital broadcasting signal input, process and output

Base & SDK layer

- Core processes for VILLAGEFLOW

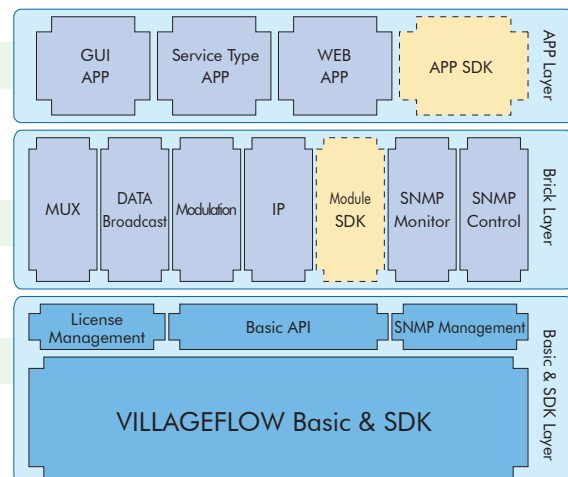

Digital TV local broadcasting system and Digital Signage

You can watch local broadcast on ordinary digital TV or HDD recorder, receiving signal from standard antenna, coax cable and IP network. This system is used commonly for Digital Signage (airport, horse racing, public spaces) but also for internal broadcast in hotels, schools and companies.

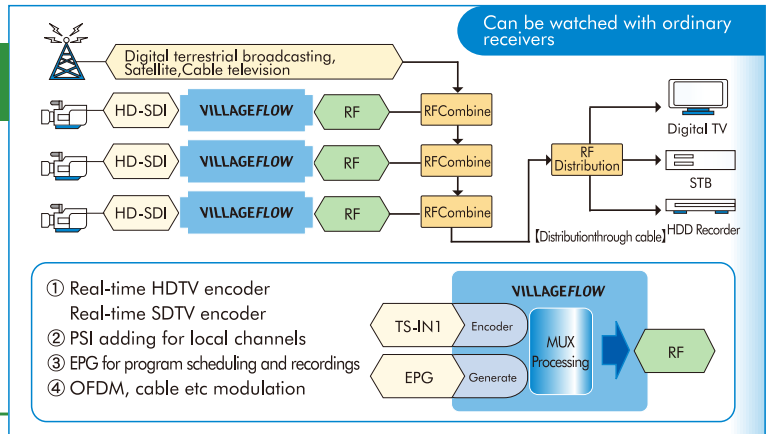

Mobile TV local area broadcasting system

You can broadcast your own Mobile TV program in a limited area. This system has started to be recognized as a new broadcasting method and is used in museums, stadiums and other public facilities.

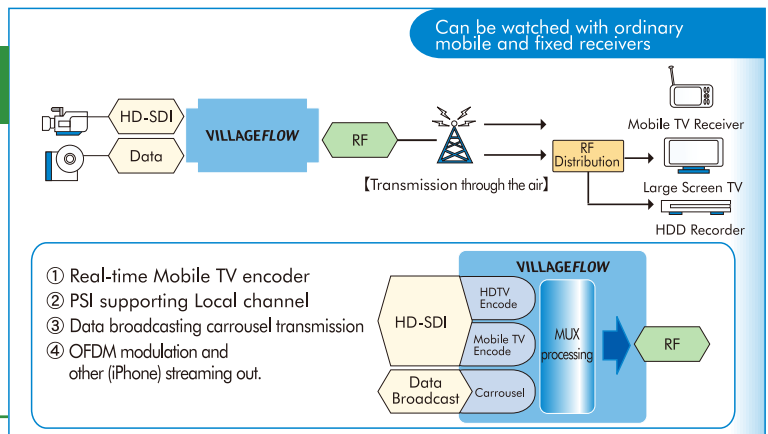

IPTV and Hybrid-IPTV transmission systems

You can transmit video from a remote location through the IP network and modulate the TV through the air where appropriate to do so.

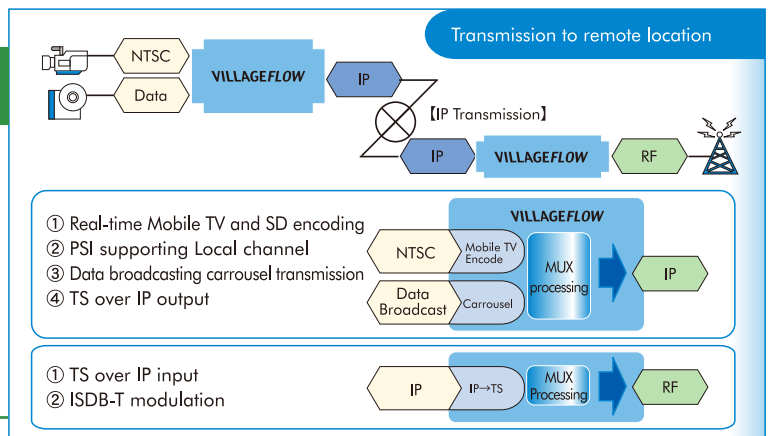

TS data validation system

VILLAGEFLOW achieves the same features as your actual broadcasting system, and allows the complete staging of your signal before bringing it "On Air". This system is used for creation of data broadcasting and testing of new service configurations.

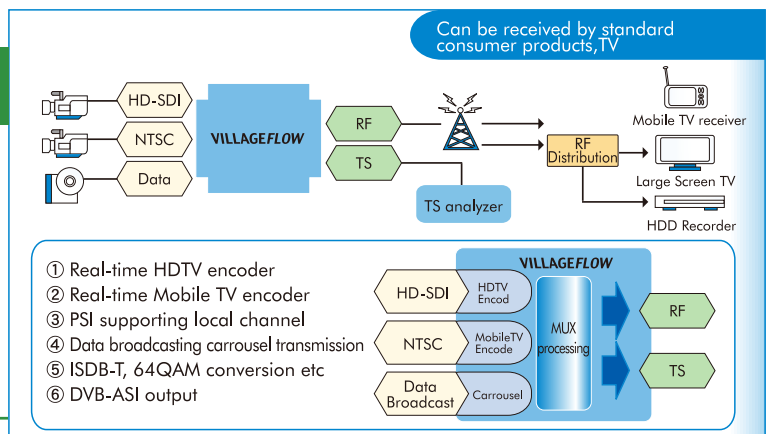

VILLAGE island Co.,Ltd.

2-38-14 Okusawa, Setagaya-ku, Tokyo 158-0083 JAPAN
Tel : (+81) 3-5654-7801/ Fax : (+81) 3-5654-7802
Email: villageflow@village-island.com

"VILLAGEFLOW (TM)" is a protected trademark of Village Island Co., Ltd, Tokyo, Japan (CERTIFICATION OF TRADEMARK REGISTRATION No: 5160758).



VILLAGE island Asia Pte Ltd

190 Middle Road, #19-05 Fortune Center, Singapore 188979
Tel: (+65) 6826-1050/ Fax: (+65) 6826-1051
E-mail: villageflow@village-island.com

VILLAGE island Asia Pte Ltd is exclusive reseller for Singapore, India, Australia, Malaysia, Thailand, Vietnam, Philippines, Indonesia, Brunei, Cambodia, Burma, Laos, Nepal, India, Australia, New Zealand