

DTA-2116

| All-Standard 0-3GHz Modulator

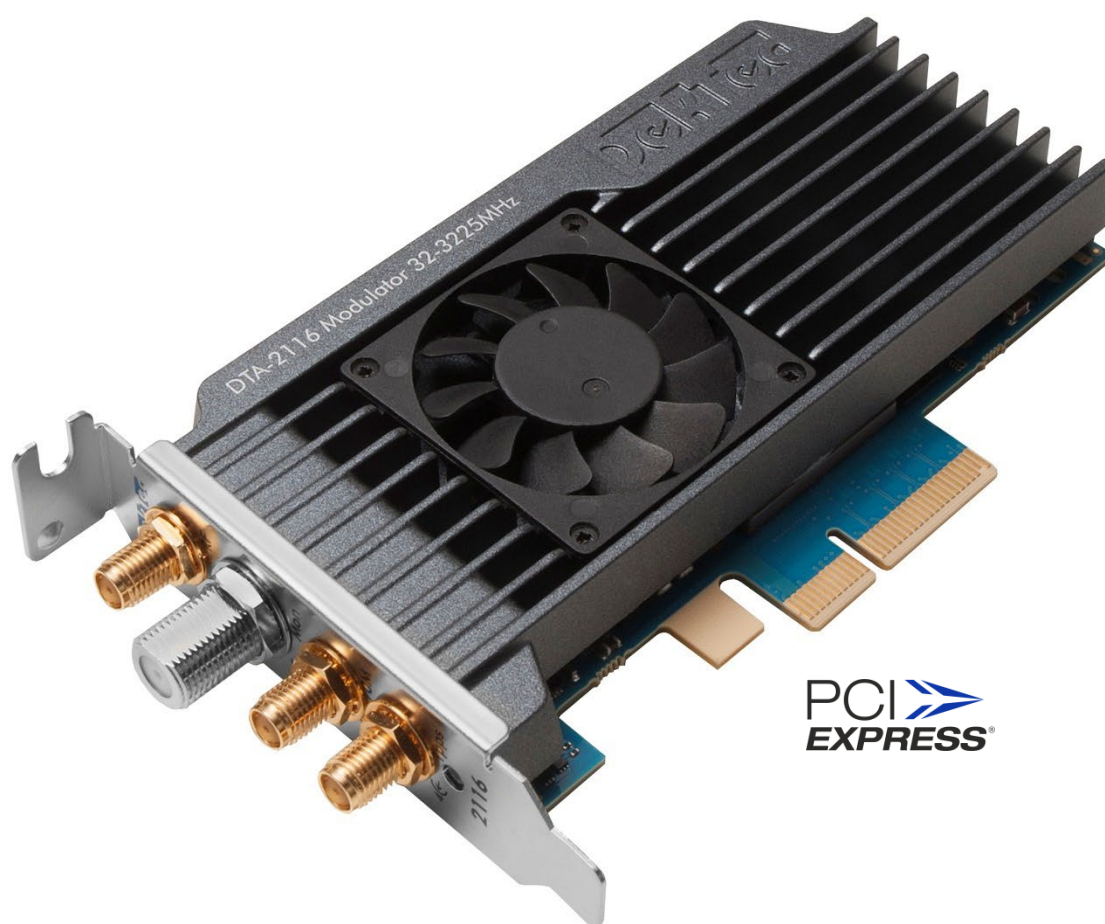

DATASHEET

March 2023

DeKtec

Table of Contents

1. Introduction	4
1.1. General Description	4
1.2. Applications	4
1.3. Standard Applications for the DTA-2116 Provided by DekTec.....	6
1.4. Developing Custom Applications for the DTA-2116	6
2. Options Available for the DTA-2116	7
3. Block Diagram	8
4. Specifications	9
4.1. Ports	9
4.2. RF Outputs	9
4.3. Reference Clock Inputs.....	10
4.4. RF and Modulation Parameters.....	11
4.5. Miscellaneous Specifications.....	12
4.6. EMC Compliancy.....	12
5. Modulator Synchronization	13
5.1. Introduction	13
5.2. Frequency Synchronization	13
5.2.1. Master Clock Generator	13
5.2.2. Selecting the Internal or External Reference Clock	14
5.2.3. Selecting the Clock Source in DtlInfo	14
5.3. Synchronization Modes	15
5.4. 1 pps Mode.....	15
5.4.1. 1 pps Mode – Applications	15
5.4.2. 1 pps Mode – Methods for Achieving Time Synchronization.....	17
5.4.3. 1 pps Mode – Timing of the 1 pps Signal	18
5.4.4. 1 pps Mode – Synchronization Modes	19
5.4.5. 1 pps Mode – Transmitting Data	20
5.4.6. 1 pps Mode – Monitoring Phase	20
5.5. Trigger Mode.....	21
5.5.1. Trigger Mode – Applications	21
5.5.2. Trigger Mode – Timing	22
5.5.3. Trigger Mode – Transmitting Data.....	23
6. Modulation Standards	24
6.1. ATSC 1.0	24
6.2. ATSC 3.0	24
6.3. ATSC-MH.....	25
6.4. CMMB	25
6.5. DAB(+)/T-DMB.....	26
6.6. DRM(+).....	26
6.7. DTMB (ADTB-T, DMB-T/H)	27
6.8. DVB-C2	27
6.9. DVB-CID	28
6.10. DVB-S	28
6.11. DVB-S2	29
6.12. DVB-S2X	30
6.13. DVB-T/H	31
6.14. DVB-T2	31
6.15. I/Q Samples.....	32
6.16. ISDB-S.....	32

6.17. ISDB-S3.....	33
6.18. ISDB-T/T _{SB}	33
6.19. ISDB-Tmm.....	34
6.20. QAM-A (DVB-C)	34
6.21. QAM-B	35
6.22. QAM-C (ISDB-C)	35
7. Performance Measurements	36
7.1. Phase Noise	36
7.2. Return Loss.....	41
7.3. Adjacent Channel Power	42
7.4. Shoulder Attenuation.....	43

1. Introduction

1.1. General Description

The DTA-2116 is a versatile high-end modulator that is designed to support a wide range of cable, terrestrial and satellite modulation standards, including ATSC 3.0, DVB-S2X, and DVB-T2. It comes in the form of a low-profile PCI Express card that allows users to modulate one channel with up to 100MHz bandwidth and upconvert it to any frequency between 32-3225MHz. Moreover, the modulator can be synchronized to a 10MHz/1pps clock for SFN operation, and it can be triggered to start multiple modulators simultaneously, for example, for GPS simulators.

The DTA-2116 uses digital signal processing techniques to achieve a near-perfect modulated RF signal, and its all-digital design ensures that every step of the modulation process including upconversion is precise and noise-free. This makes it capable of being used for any application, including actual broadcasting or uplinking to a satellite. The DTA-2116 also has advanced capabilities such as low phase noise, accurate calibrated output level, and sub-nanosecond synchronization to an external reference clock or trigger signal.

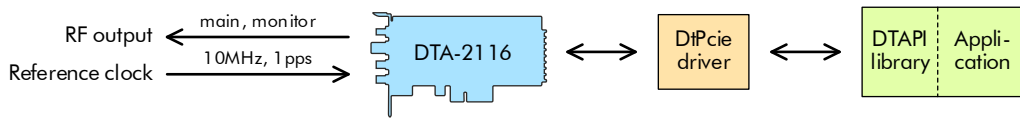

Figure 1. The DTAPI library and DtPcie driver enable applications to control the DTA-2116.

The operation of the DTA-2116 requires the use of the DtPcie driver, the DTAPI library, and an application that is linked to DTAPI. DekTec offers a variety of standard applications that support the DTA-2116 (refer to §1.3), or users can develop their own application for generating a modulated RF stream (refer to §1.4).

The DTA-2116 employs software-defined radio (SDR) techniques, providing significant flexibility compared to traditional, entirely hardware-based modulators. With SDR, the integration of new modulation standards or the implementation of new features or parameters in existing standards is made easy. Moreover, the DTA-2116's built-in channel simulator, which is a valuable tool for assessing receiver implementation margins, is enabled by SDR.

Overall, the DTA-2116 is a reliable, flexible, and powerful modulator that can be used in a variety of scenarios where high-quality modulated signals are required.

1.2. Applications

The versatility of the DTA-2116 modulator makes it a valuable tool for numerous applications in the broadcast and other industries. One of the primary applications is as a test modulator for sending modulated test streams to DTV products during development. Figure 2 demonstrates how developers can conveniently send modulated streams to DTV equipment right from their desk using the DTA-2116.

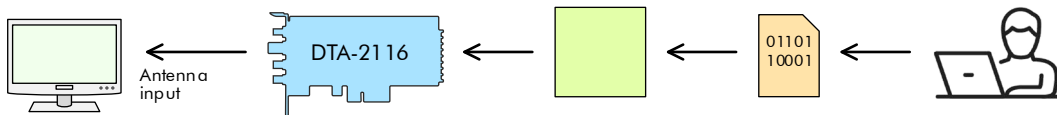

Figure 2. The DTA-2116 enables developers to send modulated streams to DTV equipment right from their desk.

In addition to its use in the development process, the DTA-2116 modulator is also useful for engineers and technicians involved in automated testing. By using the modulator's remote-control interface via StreamXpress, an automatic test program can cycle through a sequence of test patterns that are modulated at different frequencies and levels.

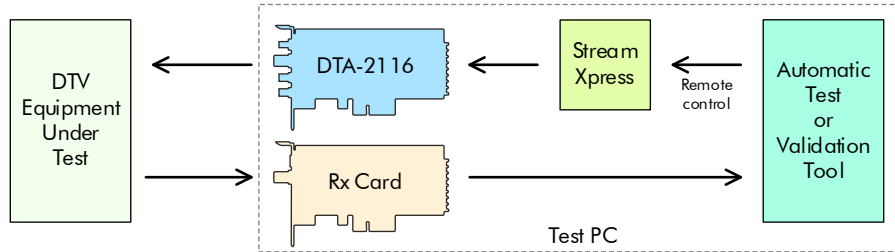

Figure 3. The DTA-2116 utilized in an automated test setup, using StreamXpress with remote control.

This setup is ideal for conducting validation or characterization tests for newly developed equipment in a lab setting or for conducting duration tests in a climate chamber. The DTA-2116's output level is programmable with a wide range, which can enhance the efficiency and accuracy of the equipment testing process.

Similarly, the modulator can be used at the end of a production line in a factory to automatically test equipment that has just been produced. This ensures that the product meets the required specifications and is functioning as intended before it is shipped to customers.

The modulator's ability to synchronize with an external clock reference with exceptional accuracy is a unique feature that opens up a wide range of interesting applications.

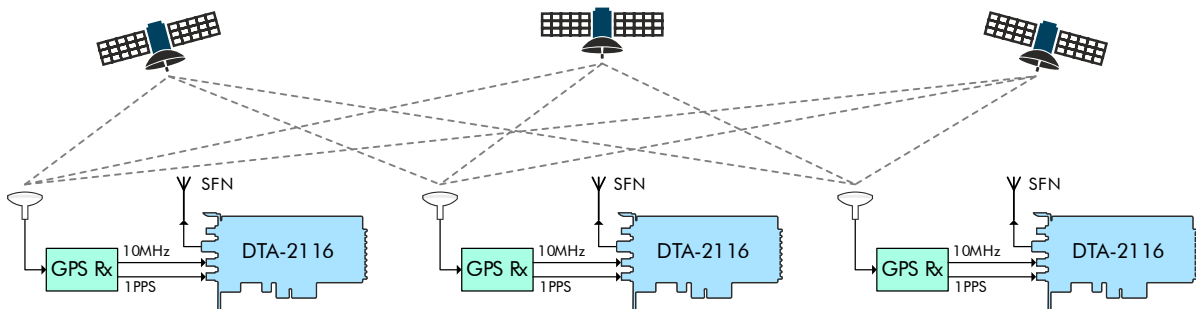

Figure 4. The synchronization feature of the DTA-2116 used in a Single Frequency Network (SFN).

Multiple modulators can operate simultaneously with close to perfect synchronization, allowing for single-frequency networks (SFN) or multi-transmitter antenna simulations. This feature also enables the creation of complex systems where multiple modulators need to work together with a high degree of synchronization.

In addition to these applications, the DTA-2116 is also suitable for research and advanced development applications. Its flexibility and advanced capabilities make it an ideal platform for developing and testing new modulation schemes, as well as conducting research in the field of communications.

1.3. Standard Applications for the DTA-2116 Provided by DekTec

DekTec provides several standard applications for the DTA-2116. To run these applications, specific options (licenses) must be present in the non-volatile memory of the board. Refer to §2 for a description of options and the corresponding ordering codes. The following table lists the available applications and their descriptions:

Application	Options required	Description
<i>StreamXpress</i>	-SP -RC (optional)	Allows playback and modulation of streams from file with a user-friendly interface that enables setting all modulation and channel simulation parameters. It also offers convenient controls for starting, stopping, and pausing, as well as a slider for quick navigation. The -RC option enables remote control of the StreamXpress via SOAP.
<i>MuxXpert</i>	-MX	Enables real-time remultiplexing of live transport streams and content from files, which is then modulated into an RF stream using the DTA-2116.
<i>Atsc3Xpress</i>	-SP, -A3	Allows the creation of broadcast-quality ATSC 3.0 signals with complete control over virtually all ATSC 3.0 parameters, including support for advanced features such as subframes, multi-PLP and a variety of PLP-multiplexing strategies.
<i>C2Xpress</i>	-SP, -C2	DVB-C2 test-signal generator that supports all DVB-C2 parameters.
<i>T2Xpress</i>	-SP, -T2	An industry standard DVB-T2 test-signal generator that supports all DVB-T2 parameters. This application enables the creation of multi-PLP signals, T2 lite, T2-MI, and any other T2 configurations you can think of.
<i>TmmXpress</i>	-SP, -I	ISDB-Tmm test-signal generator that supports all ISDB-Tmm parameters.

Note that the DTA-2116 with GOLD option (DTA-2116-GOLD) includes all applications in the table above, except *MuxXpert*, which must be ordered separately.

The following table lists the order codes required to purchase applications from DekTec.

Option	Order code	Note
-SP	DTC-300-SP	The DTA-2116 with this option included can be ordered as DTA-2116-SP. Ordering the DTA-2116 without the -SP option is only advisable if you plan to develop a custom application or use MuxXpert (-MX).
-RC	DTC-302-RC	Remote control option for StreamXpress.
-MX	DTC-700-MX	

1.4. Developing Custom Applications for the DTA-2116

Developers can create custom applications for the DTA-2116 using the free SDK provided by DekTec. The SDK is available for both Windows and Linux. It includes a device driver and the DTAPI library, which allows you to create applications that directly generate an RF output signal. This signal can be connected to the antenna input of a digital radio or TV device.

The device driver implements low-level operations that require direct access to the DTA-2116 hardware. This includes the initiation and coordination of DMA transfers, the handling of interrupts and reading and writing of Vital Product Data (VPD). Developers don't need to be aware of the driver functions as they are abstracted by the DTAPI library.

2. Options Available for the DTA-2116

The DTA-2116 supports a wide range of modulation standards. However, certain modulation standards and features require additional "options", which are essentially licenses stored in the board's non-volatile memory. These options can be purchased from DekTec and users can program these licenses in the field. It is important to note that certain modulation standards and features are included in the base product and do not require the purchase of an option.

The following table lists the available options for the DTA-2116, along with their order codes and remarks. It is worth mentioning that the "Included" remark means that the option is already included in the base product and no additional license is required.

Feature	Option	Order code	Remark
ATSC 1.0		<i>Included*</i>	
ATSC 3.0	-A3	DTC-386-ATSC3	
ATSC-MH	-MH	DTC-377-MH	
Channel simulation	-CM	DTC-305-CM	AWGN and multipath emulation
CMMB	-C	DTC-375-CMMB	
DAB	-E	DTC-376-DAB	Also enables DRM(+)
DTMB	-D	DTC-374-DTMB	
DVB-C2	-C2	DTC-379-C2	
DVB-CID		<i>Included*</i>	
DVB-S		<i>Included*</i>	
DVB-S2		<i>Included*</i>	
DVB-S2X	-S2X	DTC-383-S2X	
DVB-T		<i>Included*</i>	
DVB-T2 full	-T2	DTC-378-T2	
DVB-T2 single-PLP		<i>Included*</i>	
GOLD	-GOLD	GOLD	Enables all current and future modulation options
GPS clock sync		<i>Included*</i>	Synchronize to a 1pps/10MHz timing reference
I/Q samples	-Q	DTC-371-IQ	
ISDB-S	-IS	DTC-373-IS	
ISDB-S3	-IS3	DTC-387-ISDBS3	
ISDB-T	-I	DTC-370-ISDB	
ISDB-Tmm	-IM	DTC-382-TMM	
QAM-A		<i>Included*</i>	ITU J.83 Annex A, also known as DVB-C
QAM-B		<i>Included*</i>	ITU J.83 Annex B
QAM-C		<i>Included*</i>	ITU J.83 Annex C

* "*Included*" means that the option is included in the base product and that no special license is required.

The **GOLD** option includes all currently available options and any future options that DekTec may develop for the DTA-2116. By purchasing the GOLD option, users can unlock the full potential of the DTA-2116 without worrying about purchasing additional licenses for any future modulation standards or features.

The GOLD option is an excellent choice for users who require maximum flexibility and future-proofing. However, it may not be necessary for users who only require a specific set of modulation standards and features. Users should carefully evaluate their requirements and select the appropriate option(s) accordingly.

3. Block Diagram

The DTA-2116 is a versatile modulator that generates a high-quality modulated RF signal. Unlike traditional analog modulators, the DTA-2116 performs all signal processing in the digital domain, providing greater flexibility and precision. The figure below illustrates the functional block diagram of the DTA-2116.

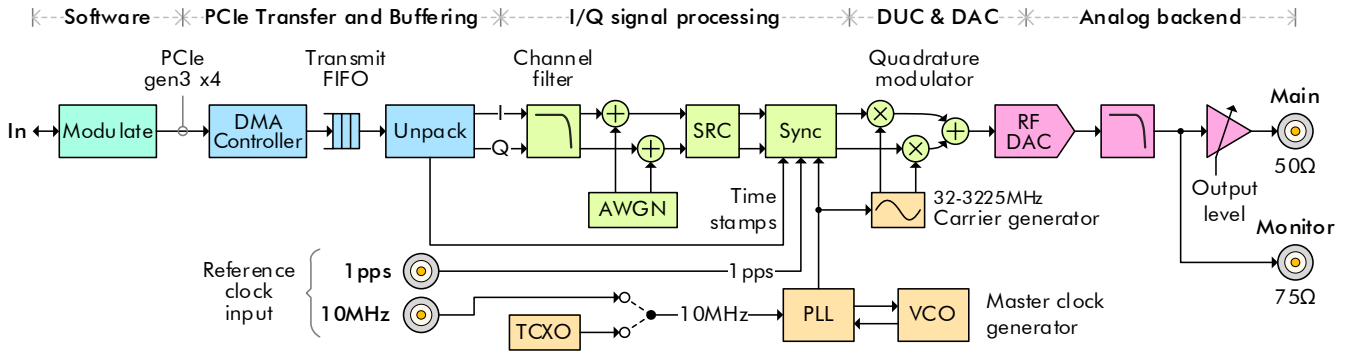

Figure 5. Functional block diagram of the DTA-2116.

Software Modulation

The modulation process starts in software, where most of the necessary modulation steps are executed, converting the input stream into raw I/Q samples. The software then packages these I/Q samples into packets and adds timestamps if the RF output needs to be synchronized with the output of other modulators.

PCIe Bus Transfer and Buffering

The DTA-2116 receives I/Q packets over the PCI Express bus via the on-board DMA controller. The I/Q samples are buffered in a DDR memory-based transmit FIFO, ensuring a continuous stream of samples without interruptions, even when the PCIe bus handles other. The unpacker recovers the I/Q samples and extracts the timestamps from the packet for synchronization purposes.

I/Q Signal Processing

This stage involves the following steps.

- Filtering of I/Q samples using a programmable channel filter, which can be programmed with a root-raised-cosine filter for single-carrier modulation standards or with a standard low-pass filter for OFDM-based standards. The resulting output is a modulated baseband signal in the digital domain.
- Optional addition of noise to the I/Q samples for channel simulation purposes using a digital noise generator with a programmable level.
- I/Q resampling to align with the master clock sample positions using a Sample Rate Converter (SRC).
- Gating of the output signal using a Sync block to enable starting synchronous with the 1 pps input signal.

DUC and DAC

A digital upconverter (DUC) multiplies the I and Q samples with the carrier and the 90-degree shifted carrier, resulting in a digitally upconverted modulated signal. A high-performance Digital-to-Analog Converter (RF-DAC) then converts this signal into an analog RF signal directly at the required carrier frequency.

Analog backend

Finally, the output of the RF-DAC is low-pass filtered and amplified or attenuated with a programmable gain.

Master clock generator

The master clock generator synchronizes the DTA-2116's master clock oscillator to an internal 10MHz oscillator, or to a 10MHz external reference clock input.

4. Specifications

4.1. Ports

You can find a description of the available ports on the bracket of the DTA-2116 in the table below.

Bracket	Port	Label	Connector	Ohm	Description
	1	RF	SMA female	50Ω	Main RF output. Outputs the modulated RF signal, at a software programmable level.
	2	Mon	F-type female	75Ω	Monitoring output. Provides the same signal as the main RF output, but at a fixed level of around -50dBm. It can be connected directly to the antenna input of a digital TV device using an F type cable.
	3	10M	SMA female	50Ω	10MHz reference clock input. Synchronizes the frequency of the DTA-2116's on-board master clock generator.
	4	1pps	SMA female	50Ω	1 pulse-per-second or trigger input. Triggers playout or synchronizes the phase of the modulated RF signal.

4.2. RF Outputs

The modulated signal is available on two output connectors:

- On a 50-Ω main output with programmable RF level;
- On a 75-Ω monitor output with fixed RF level.

The characteristics of the outputs are specified in the table below.

	Qualification	Min	Typ	Max	Unit
MAIN OUTPUT					
Connector type		SMA, female			
Impedance		50			Ω
Level (single carrier)	32 .. 1000MHz	-90*		-2	dBm
	1000 .. 3225MHz	-90*		-9	dBm
Level (OFDM)	32 .. 1000MHz	-90*		-5	dBm
	1000 .. 3225MHz	-90*		-12	dBm
Level, step size			0.1		dB
Level, accuracy			±0.2	±0.8	dB
Return loss		12	20		dB
Max. allowable DC level**				50	V
MONITOR OUTPUT					
Connector type		F-type, female			
Impedance		75			Ω
Level (fixed)	DVB-S2X, ISDB-S(3), QAM	-53	-47	-45	dBm
Level (fixed)	OFDM	-56	-50	-48	dBm
Return loss		10			dB

* Please note that for output levels lower than approximately -75dBm, digital attenuation is utilized. While this technique effectively lowers the signal level, it may also result in some degradation of signal quality at very low levels.

** Connecting a signal with a DC level up to the specified maximum voltage to the output of the DTA-2116 will not cause damage, making it safe to connect the DTA-2116 directly to a satellite receiver that injects DC voltage on the antenna input to power an LNB.

4.3. Reference Clock Inputs

The DTA-2116 can be synchronized with an external clock generator or GPS clock using the 10MHz and 1pps reference clock inputs, see the table for the electrical specifications. For detailed information on the use of the synchronization inputs, please refer to Section 5.

Parameter	Qualification	Min	Typ	Max	Unit
10MHz INPUT					
Connector type		SMA, female			
Impedance		50			Ω
V_{in}	Absolute maximum	-0.3		+3.6	V
	Operating range	0.0		+3.3	V
Voltage swing	Absolute maximum			1700	mVpp
	Operating range	20		1000	mVpp
1pps INPUT					
Connector type		SMA, female			
Impedance		6.6			k Ω
Coupling		DC			
V_{in}	Absolute maximum	-0.3		+5.5	V
V_{in} (high)		0.82			V
V_{in} (low)				0.8	V

To achieve the most accurate modulator synchronization, DekTec recommends connecting a square wave with a fast-rising edge to the 10MHz clock input. The speed of the rising edge directly impacts the precision of the synchronization: faster edges yield greater accuracy. Additionally, a larger voltage swing generally reduces noise and jitter, though this effect is less pronounced than the impact of the rising edge speed.

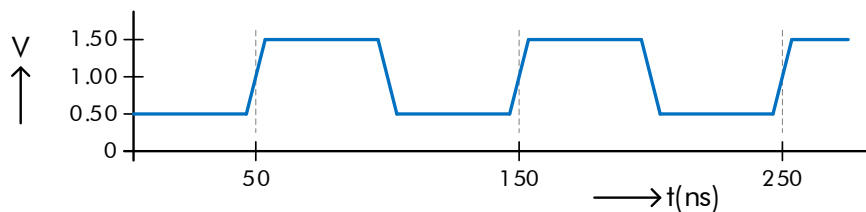

Figure 6. Example of a valid clock signal connected to the 10MHz input.

4.4. RF and Modulation Parameters

The table below provides detailed specifications on the characteristics of the modulated signal produced by the DTA-2116 modulator.

Parameter	Qualification	Min	Typ	Max	Unit
RF FREQUENCY					
Range*	Envelope spectrum	32		3225	MHz
INTERNAL CLOCK**					
Initial accuracy	25°C	-0.5		+0.5	ppm
Aging in first year		-1		+1	ppm
Stability	0 to 40°C ambient	-0.5		+0.5	ppm
Step size			1		Hz
Phase noise	50MHz, 10kHz offset		-129		dBc
	1000MHz, 10kHz offset		-123		dBc
	2000MHz, 10kHz offset		-117		dBc
	3000MHz, 10kHz offset		-115		dBc
MODULATION					
Bandwidth				100	MHz
MER	Equalized, 8MHz QAM	48	55		dB
	Equalized, 36MHz QPSK	47	55		dB
	Note equalized, 8MHz QAM	38	45		dB
	Not equalized, 36MHz QPSK	32	40		dB
SIGNAL PURITY					
Spectral purity	32 to 1000MHz	50			dB
	1000 to 3225MHz	45			dB
Adjacent channel power				-60	dB
Shoulder attenuation	OFDM			-60	dB
CHANNEL SIMULATOR					
SNR, range	DVB-S/S2, ISDB-S/S3	3		30	dB
	DVB-S2X	-10		30	dB
	All other standards	-10		100	dB
SNR, step size			0.1		dB
SNR, accuracy	DVB-S/S2, ISDB-S/S3	±1			dB
	All other standards	±0.2			dB

* The DTA-2116 modulator generates frequencies within the specified range, but the carrier frequency range is narrower due to half the bandwidth being added to both sides of the carrier frequency, resulting in a reduced range.

** When using an external clock reference, the device's internal clock specifications are irrelevant, and the specifications of the external clock signal become crucial.

4.5. Miscellaneous Specifications

Parameter	Qualification	Min	Typ	Max	Unit
POWER					
Supply rails used			3.3, +12		V
Power consumption		11		16	W
	Card is idle		11		W
	Modulating one channel		15.8		W
PCI EXPRESS BUS					
Label			PCIe3 x4		
Profile			low profile		
MECHANICAL					
Dimensions	L x H x D card only		136.2 x 69.1 x 17.9		mm
Weight			197		g
ENVIRONMENTAL					
Operating temperature		0		+45	°C

4.6. EMC Compliancy

DekTec has conducted testing on the DTA-2116 modulator card installed in a compliant PC to verify compliance with relevant CE and FCC regulations in the area of electromagnetic compatibility (EMC). The tests, performed at a certified EMC lab, confirm that it is possible to integrate the DTA-2116 in a PC in a way that ensures the integrated system is EMC compliant, meeting the required standards for compliance with CE and FCC regulations.

However, it's important to note that the responsibility for verifying and declaring compliance with applicable regulations in the markets where the integrated product is sold lies with the integrator. DekTec cannot be held responsible for any issues that arise because of non-compliance. Therefore, it's essential that the integrator conducts their own testing and validation to ensure compliance with local regulations before selling the integrated product in the market.

A declaration of CE and FCC conformity for the DTA-2116 can be downloaded from the DekTec website.

5. Modulator Synchronization

5.1. Introduction

The DTA-2116 modulator has the capability to synchronize with an external timing source using the 10MHz and 1pps (1 pulse per second) timing reference inputs. While a free-running clock generator can be used, it's more common to use a GPS clock receiver as the timing source. This approach provides a practical means of achieving "global" synchronization, which is essential for Single Frequency Network (SFN) operation.

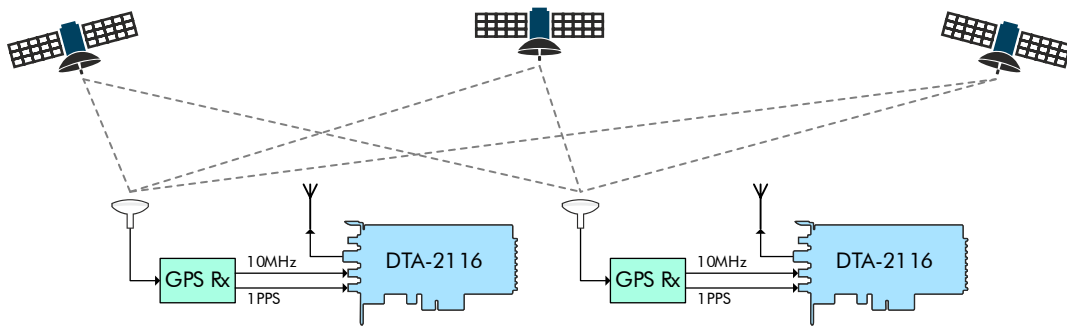

Figure 7. Multiple DTA-2116 modulators can be synchronized with the GPS clock.

The 10MHz signal is used to synchronize the *frequency* of the DTA-2116's master clock. When two DTA-2116s are locked to the same 10MHz clock, they remain synchronized over any duration. The 10MHz clock also serves as a reference for the 1pps signal, improving the precision of the detection of the rising edge of the 1pps signal.

The 1pps signal is used to achieve time synchronization, this is precise synchronization of the *phase* of the modulated signal, ensuring that it aligns with signals generated by other modulators. This synchronization is crucial for effective SFN operation.

5.2. Frequency Synchronization

Achieving optimal modulator performance requires a high-quality clock signal, which is provided by the high-performance master clock generator included on the DTA-2116.

5.2.1. Master Clock Generator

As shown in Figure 8, the DTA-2116's master clock generator consists of a Voltage Controlled Oscillator (VCO) and a low-jitter Phase-Locked Loop (PLL) that ensure the generated frequencies are locked to the reference frequency with high accuracy and stability.

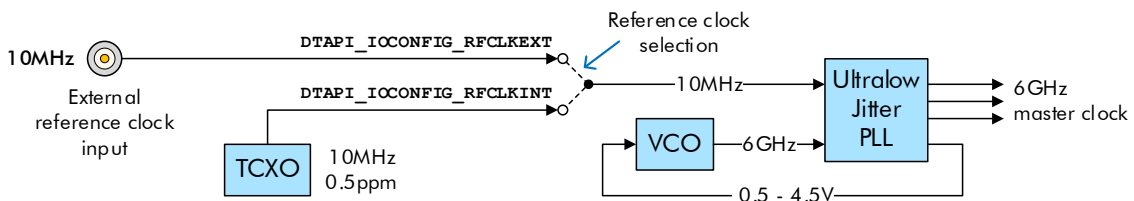

Figure 8. The DTA-2116's master clock generator syncs to an internal or external 10MHz clock.

The PLL's reference input must be a 10MHz clock signal, which can originate from either an on-board Temperature-Controlled Crystal Oscillator (TCXO) with an accuracy of 0.5ppm, or from the 10MHz clock input.

If the external reference clock input is selected but no valid 10MHz clock signal is applied, the master clock may become highly unstable, which in turn can cause significant instability in the modulated output signal.

5.2.2. Selecting the Internal or External Reference Clock

The DTA-2116 supports I/O capability RFCLKSEL, which indicates to DTAPI users that the board can be software-configured to choose between an internal and external reference clock.

```
// Check for I/O capability RFCLKEXT, which should be supported by the DTA-2116.
DtCaps Capabilities = HwFuncDesc.m_Flags;
bool RfClkExt = (Capabilities & DTAPI_CAP_RFCLKEXT) == DTAPI_CAP_RFCLKEXT;
assert(RfClkExt);
```

To actually select the desired reference source, DtDevice method SetIoConfig must be used.

```
DtDevice Dta2116;
// Code to attach the Dta2116 object to the hardware goes here.

// Select the internal reference clock (the TCXO).
// Note: the first argument '2' refers to port 2, this is the 10MHz/1pps port.
Dta2116.SetIoConfig(2, DTAPI_IOCONFIG_RFCLKSEL, DTAPI_IOCONFIG_RFCLKINT);

: : :

// Or select the external reference clock input (I/O port '10MHz').
Dta2116.SetIoConfig(2, DTAPI_IOCONFIG_RFCLKSEL, DTAPI_IOCONFIG_RFCLKEXT);
```

On Windows, the selected I/O configuration is stored in the registry after a call to SetIoConfig, allowing the I/O setting to be automatically restored upon the next time the device is attached.

On Linux, there is no similar mechanism, and the desired setting must be manually applied in the initialization code of the application driving the DTA-2116.

5.2.3. Selecting the Clock Source in DtInfo

To select the clock source for the DTA-2116 on Windows, you can use the **DtInfo** utility. In the main window, click **Change** for the target device, then go to **Advanced** and choose **Internal** or **External** as the RF clock source.

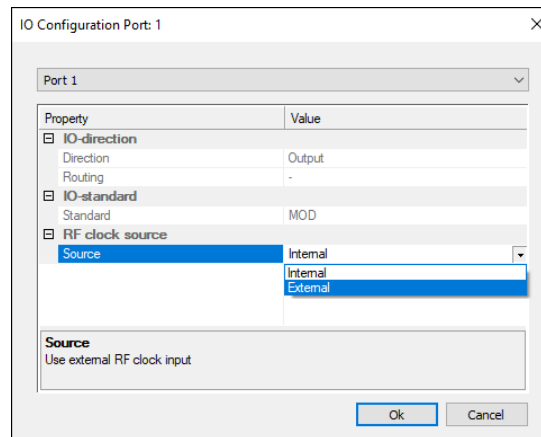

Figure 9. Synchronization of the DTA-2116's master clock generator.

When selecting the clock source in DtInfo, the SetIoConfig function is used to persist the chosen setting. This ensures that the reference clock source is maintained even when the system is rebooted or power is lost. It's essential to choose the appropriate clock source to achieve optimal performance from your DTA-2116.

5.3. Synchronization Modes

The DTA-2116 provides two synchronization modes: 1 pps Mode and Trigger Mode:

Synchronization Mode	Description	Section
1 pps Mode	The 1 pps input signal is a periodic 1 pulse per second signal that synchronizes the on-board GPS time counter. When this counter reaches a user-supplied timestamp, the RF output signal appears. Various methods for providing the timestamp are described in the subsequent sections.	§5.4
Trigger Mode	The user first <i>arms</i> the DTA-2116, and then the first rising edge of the 1 pps input signal <i>triggers</i> the start of modulation. The signal connected to the 1 pps input is typically a single pulse, although it can be of any shape, including a standard repetitive 1 pps signal. The DTA-2116 only looks at the first rising edge after arming, and any subsequent edges are ignored.	§5.5

5.4. 1 pps Mode

The DTA-2116 modulator offers two synchronization modes, one of which is 1 pps Mode. This mode allows the modulator to be synchronized to a precise timing source, such as a GPS clock receiver or a reference clock generator that generates a 10MHz clock and a 1 pps synchronization signal. The 10MHz signal is used to synchronize the frequency of the modulator's master clock, while the 1 pps signal is used to synchronize an on-board GPS time counter.

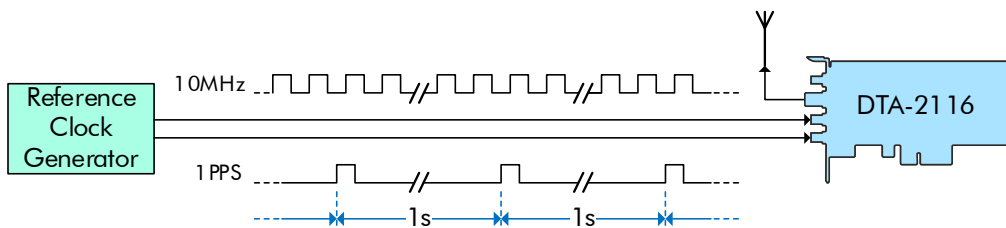

Figure 10. Synchronizing the DTA-2116 with a reference clock generator in 1 pps mode.

The picture shows the basic setup where a reference clock generator is connected to a DTA-2116 modulator to provide 10MHz and 1 pps synchronization signals for precise synchronization.

5.4.1. 1 pps Mode – Applications

1 pps Mode is useful in a variety of applications that require high precision synchronization. Here are a few examples:

- Operating or simulating a Single Frequency Network (SFN).** Single Frequency Network (SFN) is a technique used in digital television and radio broadcasting to create a network of transmitters that simultaneously transmit the same signal on the same frequency. To achieve this, the transmitters must be synchronized to a common timing source with high precision. 1 pps Mode in the DTA-2116 can be used to synchronize multiple modulators, allowing for accurate SFN operation.

The following picture shows an example setup where three GPS satellites are used to provide timing signals to three GPS receivers, which in turn provide 10MHz and 1pps signals to three DTA-2116 modulators. This setup allows for the creation of an SFN with high precision synchronization.

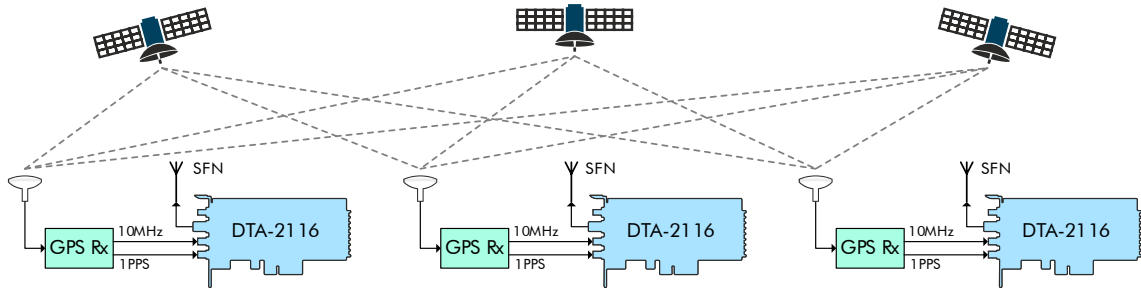

Figure 11. Multiple DTA-2116s operating in an SFN network.

- Operating or experimenting with MIMO or MISO configurations.** Multiple-input, multiple-output (MIMO) and multiple-input, single-output (MISO) configurations that use multiple transmitter antennas are becoming increasingly popular in wireless communication systems. In these configurations, the multiple transmitter antennas must be synchronized to ensure that they transmit the same signal at the same time. 1pps Mode in the DTA-2116 can be used to synchronize multiple modulators, enabling MIMO or MISO configurations with high precision synchronization.

The following picture shows an example setup where a local clock generator is used to provide 10MHz and 1pps signals to three DTA-2116 modulators. This setup allows for the creation of an SFN with high precision synchronization. Note that for optimal precision, the length of the 10MHz cables from the clock generator or distribution amplifier to the DTA-2116s must be carefully matched.

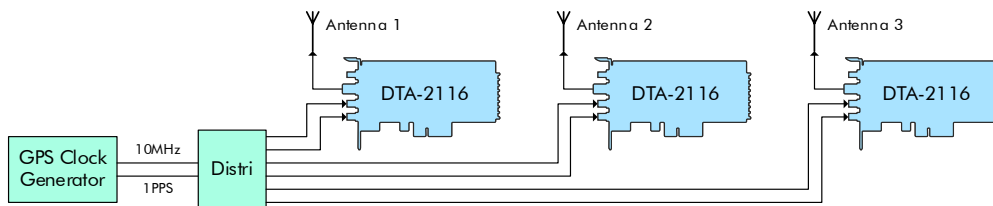

Figure 12. Multiple transmitter simulation with DTA-2116s synchronized to a local clock oscillator.

- Synchronizing a multiplexer and a modulator.** In digital video broadcasting, a multiplexer is used to combine multiple video and audio streams into a single transport stream. The transport stream is then modulated onto a carrier frequency for transmission. In a typical setup, the modulator locks to the transport rate of the multiplexer, which can cause issues when the transport rate changes.

By using 1pps Mode in the DTA-2116 to synchronize the modulator and the multiplexer, the modulator does not need to lock to the transport rate, nor do remultiplexing. This can simplify the setup and improve the overall performance and stability of the system.

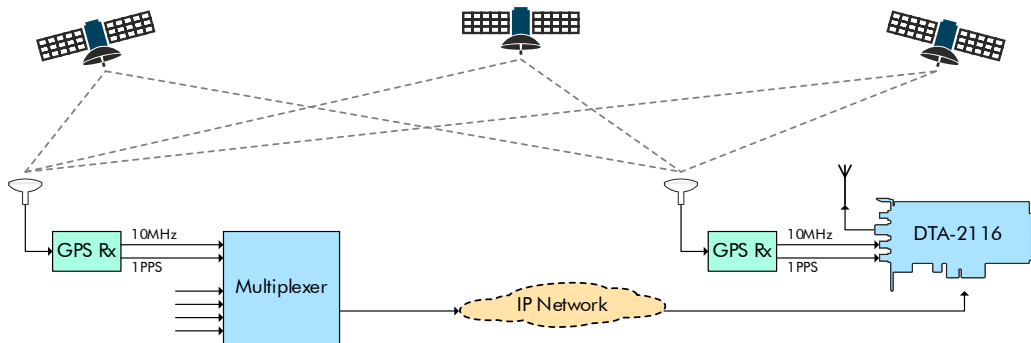

Figure 13. Synchronizing a multiplexer and a modulator to match stream rate.

Overall, 1pps Mode is a powerful feature that enables high precision synchronization in a variety of applications.

5.4.2. 1pps Mode – Methods for Achieving Time Synchronization

In 1pps Mode, there are two main methods for achieving time (=phase) synchronization:

- Timestamps Embedded in Data:** This method involves embedding timestamps into the data to be modulated. For example, in DVB-T, the time of transmission of the first OFDM symbol of each mega-frame is embedded in the Transport Stream. Similarly, in DVB-T2, the timestamp of each T2 frame is used. This approach ensures that the modulated signal is synchronized with GPS time, which is essential for Single Frequency Network (SFN) operation.
- Explicit Timestamps:** This technique involves starting transmission at a specific GPS time, eliminating the need for timestamps to be embedded in the data. This method is particularly useful for synchronized transmission of pre-computed I/Q sample streams by multiple DTA-2116 devices. Moreover, this method provides an additional benefit to the user by eliminating the need to insert timestamps in I/Q sample files.

5.4.3. 1 pps Mode – Timing of the 1 pps Signal

The 1 pps signal synchronizes the on-board GPS time counter to zero every second. To ensure accurate detection, the 1 pps pulse must maintain a minimum width of T_{pulse} . Moreover, the rising edge of the 1 pps signal should comply with a minimum lead time relative to the rising edge of the 10MHz clock.

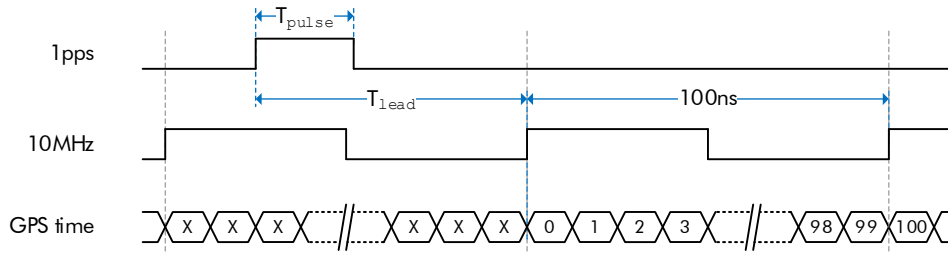

Figure 14. Resetting the GPS time counter after the 1 pps pulse.

Note – The exact moment of resetting the GPS time counter is determined not by the rising edge of the 1 pps signal, but by the first rising edge of the 10MHz clock following the 1 pps edge.

The table below lists the timing parameters.

Parameter	Min	Typ	Max	Unit	Description
T_{pulse}	10			ns	Pulse width of the 1 pps signal.
T_{lead}	5*		95*	ns	Lead time of the 1 pps signal's rising edge prior to the 10MHz signal's rising edge.

* This value assumes that the 50ns delay addition mode for the 1 pps signal is not enabled.

** The valid range for T_{offset} depends on the selected SFN mode.

1 pps 50ns Addition Mode

In instances where the rising edges of the 1 pps and 10MHz signals coincide for a specific timing source, the DTA-2116 can introduce a 50ns delay to the 1 pps signal to ensure sufficient timing margin. This feature is called *1 pps 50ns Addition Mode* and is **enabled** by default.

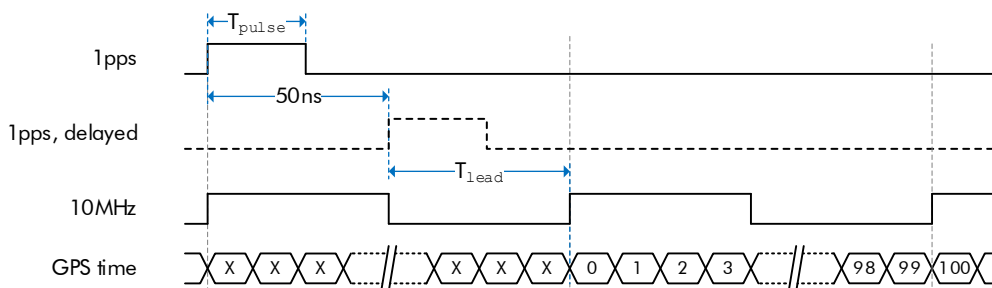

Figure 15. In *1 pps 50ns Addition Mode*, a 50ns delay is added to the 1 pps signal, creating the required timing margin.

By delaying the rising edge of 1 pps by 50ns, T_{lead} can be easily met. Enabling or disabling *1 pps 50ns Addition Mode* allows support for any timing source, irrespective of the phase relation between the 1 pps and 10MHz signals.

Important – Users must carefully choose either 0 or 50ns for the 1 pps signal. An incorrect selection may result in significant jitter in corner cases.

5.4.4. 1pps Mode – Synchronization Modes

The synchronization process begins when the user sets Transmit Control to SEND, known as the “SEND event”. Subsequently, the DTA-2116 calculates the modulation start time and starts transmission when the on-board GPS time counter matches this start time. A time offset can be specified and added to the start time to adjust the exact starting moment for earlier or later RF output.

Note – Unless stated otherwise, all time computations are carried out modulo one second, ensuring that time values always fall within the 0 to 1-second range.

The method for determining the start time depends on the specific submode of the 1pps Mode. The table below outlines this process for each submode and shows the valid range of the time offset that can be specified.

Submode*	Time offset	Description
DISABLED	-	The modulator operates without any synchronization to a timing source.
AT_1PPS	0 .. 1s	No timestamp is used; the start time is determined by the time offset. After the SEND event, the DTA-2116 waits for the GPS time to match the start time, which cannot take more than one second. A “too late” event is impossible in this submode.
IQPKC	0	This mode is designed for use with an I/Q packet stream containing embedded timestamps, where transmission begins at the timestamp indicated in the first I/Q packet. After the SEND event, the hardware extracts the first timestamp and waits for the GPS time to match this timestamp. If the hardware must wait for more than 0.5 seconds, a “too late” event is generated.
DVBT_MIP	-0.5s .. 0.5s	This mode is designed for DVB-T streams, aiming to align the DTA-2116's RF output to the synchronization timestamp in the DVB-T MIP (Mega-frame Initialization Packet). Following the SEND event, the DTA-2116 disregards all data in the stream until it locates the first MIP, from which the synchronization timestamp is extracted. The time offset is added, followed by a modulo 1-second operation. The result is a start time within the 0 to 1-second range. Following this, the hardware waits for the GPS time to match this start time, and transmission starts. A “too late” event is impossible in this submode. If data with the MIP is written to the DTA-2116 too late, the entire transmission will be 1 second late.
T2MI	-0.5s .. 0.5s	Operates similar to DVB-T (submode DVBT_MIP), but intended for DVB-T2. DVB-T2 timestamps can be either absolute or relative. If the first timestamp encountered is relative, then the operation follows the same process as DVB-T. However, if the first timestamp is absolute, DTAPI will not clip to a 0-1s window but instead use absolute time. This can result in a “too late” event being generated, indicating that the absolute start time lies in the past.
TRIGGER	0 .. 2.147s	

* In DTAPI, submodes are prefixed with DTAP_SFN_MODE_, e.g. AT_1PPS becomes DTAP_SFN_MODE_AT_1PPS.

5.4.5. 1pps Mode – Transmitting Data

The standard method for streaming to a DekTec card, described in Section 3.6 of the “DTAPI - Overview and Data Formats”, involves setting Transmit Control to HOLD, writing data to the transmit FIFO to build up an initial load, and then setting Transmit Control to SEND. However, in 1pps Mode, a distinct method is required.

First, set the desired 1pps submode, set Transmit Control to SEND, and then begin sending data. DTAPI and the DTA-2116 will establish the start time, wait until GPS time matches the start time, and start transmission. The code example below illustrates the sequence of DTAPI calls required for this process. In this example, we use the DTAPI_SFN_MODE_DVBT_MIP mode, where synchronization relies on timestamps derived from the DVB-T MIP (Mega-frame Initialization Packets) found in the input stream.

```
// PRECONDITIONS:
// 1. Dta2116Chan is a DtOutpChannel object that has been attached to the hardware.
// 2. A valid modulation mode and valid modulation parameters have been set.
// 3. Transmit Control is IDLE.

// Set the 1pps submode to "timestamps derived from the DVB-T MIP".
int TimeOffset = -100; // Example negative time offset of 100ns.
Dta2116Chan.SetSfnControl(DTAPI_SFN_MODE_DVBT_MIP, TimeOffset);

// SEND event: Switch Transmit Control from IDLE to SEND.
// This requires valid 10MHz and 1pps input signals, otherwise an error will be returned.
Dta2116Chan.SetTxControl(DTAPI_TXCTRL_SEND);

// Main loop.
while (!StopCondition())
{
    Dta2116Chan.Write(DataBuffer, BUFSIZE);
    GetData(DataBuffer, BUFSIZE);
}
```

Note The above code example is provided for illustrative purposes only and is not intended for production use. In a production environment, it is essential to thoroughly check the return values of any methods to ensure that DTAPI operates as expected.

5.4.6. 1pps Mode – Monitoring Phase

In the monitoring phase, the DTA-2116 hardware continuously monitors the transmission time to ensure that it corresponds to the time indicated by the embedded timestamps, with a specified tolerance. The hardware compares the current GPS time to the expected time based on the embedded timestamps, and if the deviation is beyond the specified margin, the hardware sets a status flag.

The specified tolerance or margin is typically in the range of a few nanoseconds, depending on the specific application and the required level of synchronization. If the deviation is within the allowed margin, the hardware continues the transmission as normal.

If the deviation between the transmission time and the embedded timestamps exceeds the specified margin, the hardware will set a status flag to indicate the error. In such cases, it is not possible to adjust the synchronization parameters or SFN mode to recover the synchronization. The only solution is to restart modulation, which will cause the hardware to synchronize to the nearest valid GPS time stamp in the input data and attempt to maintain synchronization from that point forward. It is important to note that the software must be capable of detecting and responding to such errors in a timely manner to avoid interruptions in the transmission.

5.5. Trigger Mode

The DTA-2116 offers a Trigger Mode option that provides an alternative to 1pps Mode for initiating and synchronizing modulation. In Trigger Mode, the DTA-2116's master clock is synchronized with the 10MHz reference input clock, similar to 1pps Mode. However, unlike the 1pps Mode, Trigger Mode allows for modulation to be initiated using a single pulse or rising edge trigger signal on the 1pps input (the "trigger signal").

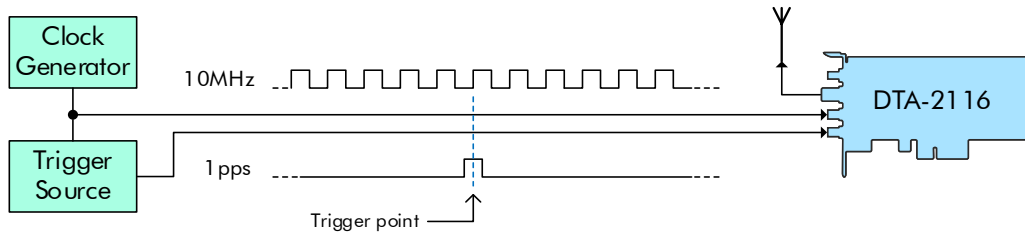

Figure 16. Triggering the DTA-2116 by using 1pps as a trigger signal.

The Trigger Mode of the DTA-2116 allows for precise synchronization of multiple units with high accuracy (within a 0.5 ns window), making it ideal for generating signals for multiple antennas and playing them out synchronously. This feature enables the DTA-2116 to effectively address applications that require synchronized modulation across multiple channels.

5.5.1. Trigger Mode – Applications

Trigger Mode has a range of potential applications, including:

- **Multi-transmit antenna (MISO, transmit diversity) simulation:** Multiple DTA-2116s can be used to play I/Q sample streams simultaneously, which is critical in simulating MISO scenarios with multiple transmit antennas.

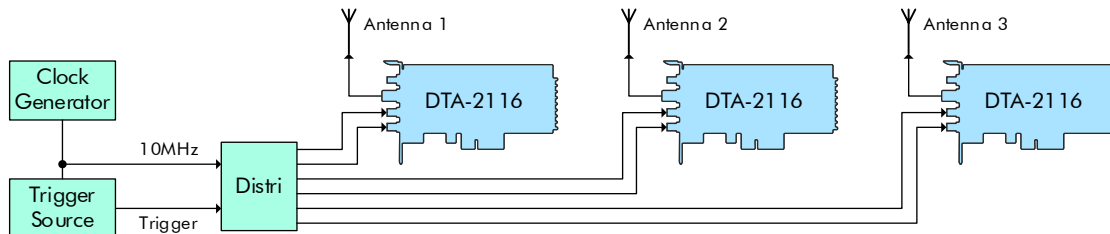

Figure 17. Transmit diversity simulation setup.

- **Multi-channel GPS and GNSS simulators:** By leveraging Trigger Mode, users can synchronize multiple DTA-2116s to emulate the signals coming from multiple satellites accurately. This capability is essential for simulating a variety of GPS and GNSS scenarios, including those with multiple channels and complex signal configurations.

5.5.2. Trigger Mode – Timing

While the timing in Trigger Mode shares similarities with the timing in 1 pps Mode, there are some differences that require separate discussion. This section provides a standalone description of the timing in Trigger Mode without reference to the timing in 1 pps Mode.

The process of triggering the DTA-2116 is illustrated in Figure 18. To initiate the trigger, the software must first "arm" the device, which prepares the DTA-2116 hardware. This arming must occur at least T_{lead} before the rising edge of the trigger signal.

The trigger signal must adhere to a setup and hold time relative to the rising edge of the 10MHz clock to ensure deterministic and accurate timing. It's worth noting that the exact moment of triggering is not the rising edge of the trigger signal, but the first rising edge of the 10MHz clock after the rising edge of the trigger signal.

In some GPS reference signal sources, the rising edges of the 1 pps and 10MHz signals can occur simultaneously. In such cases, the DTA-2116 can be configured to introduce a 50ns delay to the trigger signal to ensure sufficient timing margin. It is important to note that this 50ns delay configuration is active by default.

After triggering, there is a configurable trigger delay (T_{delay}) between the rising edge of the 10MHz clock and the appearance of the modulated signal on the RF output.

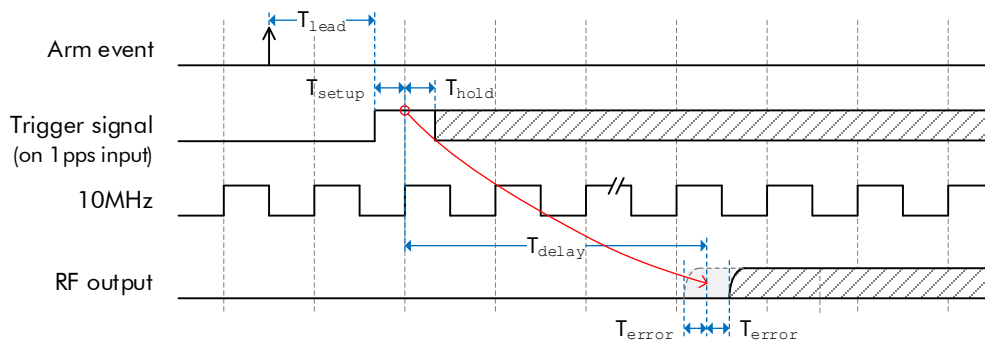

Figure 18. Timing diagram of arming and triggering I/Q payout in Trigger Mode.

Parameter	Min	Typ	Max	Unit	Description
T_{lead}	100			ms	Lead time of software arm event prior to trigger signal.
T_{setup}	5*			ns	Setup time of trigger signal before rising edge 10MHz.
T_{hold}	5*			μ s	Hold time of trigger signal after rising edge 10MHz.
T_{delay}	500**	2,147,483,647		ns	Configurable trigger delay between trigger signal and valid RF output.
T_{error}	-0.5		0.5	ns	Card-to-card difference in trigger delay time.

* The values in this table reflect the scenario where the DTA-2116 hardware does not add a 50ns delay to the trigger signal.

** The minimum time delay is dependent on the sample rate and can be obtained through the SDK with `DtOutputChannel1` method `GetSfnMinTriggerModeDelay`.

5.5.3. Trigger Mode – Transmitting Data

To transmit data in Trigger Mode, first enable Trigger Mode and set the trigger delay using DTAPI method `DtOutpChannel::SetSfnControl`. Note that the trigger delay has a minimum value that depends on the sample rate of the modulated signal. To determine the minimum trigger delay for a given sample rate, use the `DtOutpChannel::GetSfnMinTriggerModeDelay` method.

```
// PRE-CONDITIONL Dta2116Chan is attached to the hardware.

// Get the minimum trigger delay in nanoseconds.
int MinTriggerDelayNs = -1;
int SampleRate = 27500000; // Example I/Q sample rate.
Dta2116Chan.GetSfnMinTriggerModeDelay(SampleRate, MinTriggerDelay);

// Set synchronization mode to Trigger Mode and specify the desired trigger delay.
int TriggerDelay = 1000; // Example trigger delay: 1 microsecond.
assert(TriggerDelay >= MinTriggerDelay);
Dta2116Chan.SetSfnControl(DTAPI_SF_N_MODE_TRIGGER, TriggerDelay);
```

Note - The above code example is not intended for production use and is only provided for illustrative purposes. In a production environment, it is essential to thoroughly check the return values of any methods to ensure that DTAPI operates as expected.

Once the output channel has been configured with the appropriate modulation settings and Trigger Mode is enabled, data transmission is started in the same way as normal, as described in Section 3.6 of the “DTAPI - Overview and Data Formats” document. The only difference is that setting transmit control to SEND does not start transmission immediately, but instead arms transmission. The DTA-2116 will wait for the trigger signal, and when it arrives, transmission will start.

```
// PRE-CONDITIONL Dta2116Chan is attached to the hardware, modulation parameters have been set,
// Trigger Mode is enabled and the trigger delay is configured.

// Build up the initial load in the transmit FIFO of the modulator output channel.
Dta2116Chan.SetTxControl(DTAPI_TXCTRL_HOLD); // Start in HOLD mode
char DataBuffer[BUFSIZE];
for (int Load=0; Load<INITIAL_LOAD; Load+=BUFSIZE)
{
    GetData(DataBuffer, BUFSIZE);
    Dta2116Chan.Write(DataBuffer, BUFSIZE);
}

// Switch to SEND mode. In Trigger Mode, this arms the DTA-2116 for transmission.
// On the next rising edge of the 1pps trigger signal, transmission will start.
Dta2116Chan.SetTxControl(DTAPI_TXCTRL_SEND);

// Main loop.
while (!StopCondition())
{
    Dta2116Chan.Write(DataBuffer, BUFSIZE);
    GetData(DataBuffer, BUFSIZE);
}
```

Note - The above code example is not intended for production use and is only provided for illustrative purposes. In a production environment, it is essential to thoroughly check the return values of any methods to ensure that DTAPI operates as expected.

6. Modulation Standards

This section provides features, specifications and software support per modulation standard.

6.1. ATSC 1.0

Parameter / Feature	Value / Comment
STANDARD	ATSC A/53E, nowadays also known as ATSC 1.0
MODULATION PARAMETERS	
Mode	8-VSB, 16-VSB
Roll-off	0.115, programmable
FEATURES	
Input format	MPEG-2 Transport Stream
Channel simulation	AWGN insertion with adjustable SNR, multipath fading, Rayleigh channels and Doppler.
SOFTWARE SUPPORT	
<i>StreamXpress</i>	Application to play Transport Stream files and modulate in ATSC 1.0.
DTAPI SDK	SDK for creating custom applications that directly generate an ATSC 1.0 RF stream.

6.2. ATSC 3.0

Parameter / Feature	Value / Comment
STANDARD	ATSC 3.0
MODULATION PARAMETERS	
Channel raster bandwidth	6MHz, 7MHz, 8MHz
Bootstrap minor version	0 to 7
EAS wakeup	0 to 3
PARP reduction	None, ACE only, TR only, both ACE and TR
LLS present flag	On, off
Number of PLPs	Up to 64
PLP payload	PRBS, IP-capture file, live IP-input
Other ATSC 3.0-parameters	All ATSC 3.0 defined parameters
FEATURES	
Input format	PRBS IP-capture file Live IP-input
Channel simulation	AWGN insertion with adjustable SNR, multipath fading, Rayleigh channels and Doppler.
SOFTWARE SUPPORT	
<i>Atsc3Xpress</i>	Application to play and modulate single-PLP and multi-PLP ATSC 3.0 streams while having complete control over all ATSC 3.0 parameters.
DTAPI SDK	SDK for creating custom applications that directly generate an ATSC 3.0 RF stream.

6.3. ATSC-MH

Parameter / Feature	Value / Comment
STANDARD	ATSC A/153
MODULATION PARAMETERS	
Mode	8-VSB
Roll-off	0.115, programmable
FEATURES	
Input format	ATSC M/H transport stream
Channel simulation	AWGN insertion with adjustable SNR, multipath fading, Rayleigh channels and Doppler.
SOFTWARE SUPPORT	
<i>StreamXpress</i>	Application to playing Transport-Stream files and modulate in ATSC-MH.
DTAPI SDK	SDK for creating custom applications that directly generate an ATSC-MH RF stream.

6.4. CMMB

Parameter / Feature	Value / Comment
STANDARD	GY/T 220.1/2-2006
MODULATION PARAMETERS	
Bandwidth	2MHz, 8MHz
Identification	Transmitter Identification and Area Identification are freely settable
FEATURES	
Input format	CMMB-PMS stream
Channel simulation	AWGN insertion with adjustable SNR, multipath fading, Rayleigh channels and Doppler.
SOFTWARE SUPPORT	
<i>StreamXpress</i>	Application to play Transport Stream files and modulate in CMMB.
DTAPI SDK	SDK for creating custom applications that directly generate an CMMB RF stream.

6.5. DAB(+)/T-DMB

Parameter / Feature	Value / Comment
STANDARD	EN 300 401, TS 102 563 and TS 102 427
MODULATION PARAMETERS	
Modes	I, II, III, IV
FEATURES	
Input format	ETI(NI) stream according to EN 300 799
Channel simulation	AWGN insertion with adjustable SNR, multipath fading, Rayleigh channels and Doppler.
SOFTWARE SUPPORT	
<i>DabMux</i>	For multiplexing one or more audio and/or transport-stream files into an ETI(NI) stream.
<i>StreamXpress</i>	Application to play Transport Stream files and modulate in DAB(+) or T-DMB.
DTAPI SDK	SDK for creating custom applications that directly generate a DAB(+) or T-DMB RF stream.

6.6. DRM(+)

Parameter / Feature	Value / Comment
STANDARD	ETSI ES 201 980
MODULATION PARAMETERS	
Robustness modes	A, B, C, D, E
FEATURES	
Input format	Application Framing (AF) packets according ETSI TS 102 821 section 6
Channel simulation	AWGN insertion with adjustable SNR, multipath fading, Rayleigh channels and Doppler.
SOFTWARE SUPPORT	
<i>DtPlay</i>	Application to play and modulate DCP-files according to ETSI TS 102 821 Annex B.3.
DTAPI SDK	SDK for creating custom applications that generate DRM(+) directly.

6.7. DTMB (ADTB-T, DMB-T/H)

Parameter / Feature	Value / Comment
STANDARD	GB 20600-2006
MODULATION PARAMETERS	
Bandwidth	5, 6, 7, 8 MHz
Constellation	4QAM-NR, 4QAM, 16-QAM, 32-QAM, 64-QAM
Code rate	0.4, 0.6, 0.8
Guard interval	PN420, PN595, PN945
Interleaving	Mode1 (B=54, M=240), mode2 (B=54, M=720)
Frame numbering	On, off
Pilots	On, off
FEATURES	
Input format	MPEG-2 Transport Stream
Channel simulation	AWGN insertion with adjustable SNR, multipath fading, Rayleigh channels and Doppler.
SOFTWARE SUPPORT	
<i>StreamXpress</i>	Application to play Transport Stream files and modulate in DTMB.
DTAPI SDK	For creating custom applications that generate DTMB directly.

6.8. DVB-C2

Parameter / Feature	Value / Comment
STANDARD	EN 302 769
MODULATION PARAMETERS	
Channel raster bandwidth	6MHz, 8MHz
C2-system bandwidth	Up to 32MHz completely filled; up to 64MHz partly filled
Number of PLPs	Up to 255
PLP bundling	Fully supported
Number of data slices	Up to 255
PAPR reduction	None, TR
Other DVB-C2-parameters	All DVB-C2 defined parameters
FEATURES	
Input format	MPEG-2 Transport Stream GSE packets
Special simulation features	ACM and L1-update simulation
Channel simulation	AWGN insertion with adjustable SNR, multipath fading, Rayleigh channels and Doppler.
SOFTWARE SUPPORT	
<i>C2Xpress</i>	Application to play and modulate single-PLP and multi-PLP DVB-C2 streams with full control over the entire DVB-C2 parameter set.
DTAPI SDK	SDK for creating custom applications that generate DVB-C2 directly. The DTAPI supports "Multi-PLP Extensions" to easily create multi-PLP applications.

6.9. DVB-CID

Parameter / Feature	Value / Comment
STANDARD	ETSI TS 103 129 v1.1.2
MODULATION PARAMETERS	
Constellation	BPSK
Roll off	0.35
FEATURES	
Input format	DVB-CID Global Unique Identifier
SOFTWARE SUPPORT	
StreamXpress	Application to play Transport Stream files or L.3 baseband frame files, and modulate in DVB-S2/S2X, with a DVB-CID signal included.
DTAPI SDK	SDK for creating custom applications that generate DVB-S2/S2X, including DVB-CID directly

6.10. DVB-S

Parameter / Feature	Value / Comment
STANDARD	EN 300 421
MODULATION PARAMETERS	
Symbol rate	0.088MBd to 85MBd
Constellation	QPSK
Code rate	1/2, 2/3, 3/4, 5/6, 7/8
Roll off	0.35, programmable
FEATURES	
Input format	MPEG-2 Transport Stream
Channel simulation	AWGN insertion with adjustable SNR
SOFTWARE SUPPORT	
StreamXpress	Application to play Transport Stream files and modulate in DVB-S.
DTAPI SDK	SDK for creating custom applications that generate DVB-S directly

6.11. DVB-S2

Parameter / Feature	Value / Comment
STANDARD	EN 302 307-1
MODULATION PARAMETERS	
Symbol rate	0.1MBd to 125MBd
Constellation	QPSK, 8PSK, 16APSK, 32APSK
Constellation amplitude	E=1, R=1 (for 16APSK, 32APSK)
Code rate	All DVB-S2 defined code rates
FEC-frame size	Normal, short
Pilots	On, off
Roll-off	0.20, 0.25, 0.35, programmable
CCM	Default modulation mode
VCM, ACM, multiple streams, generic streams, null-packet deletion	Supported through L3 baseband frames. The frames specify the transmission format and the user data. Baseband frames can be created with a custom mode-adaptation application or through DekTec's L3Mux utility. The resulting L3 file can be played using the StreamXpress player or using a custom application via the DekTec DTAPI.
FEATURES	
Input format	MPEG-2 Transport Stream L3 baseband frames
Channel simulation	AWGN insertion with adjustable SNR
SOFTWARE SUPPORT	
<i>L3Mux</i>	Utility for creating L3 baseband frame files
<i>StreamXpress</i>	Application to play Transport Stream files, L3 baseband frame files, or IP-capture files and modulate in DVB-S2.
DTAPI SDK	SDK for creating custom applications that generate DVB-S2 directly.

6.12. DVB-S2X

Parameter / Feature	Value / Comment
STANDARD	EN 302 307-2
MODULATION PARAMETERS	
Symbol rate	0.1 .. 125MBd
Constellation	QPSK, 8PSK(-L), 16/32/64/128/256APSK(-L)
Constellation VL-SNR	QPSK, BPSK(-S)
Code rate	All DVB-S2X defined code rates
FEC-frame size	Normal, medium, short
Pilots	On, off
Roll-off	0.05, 0.10, 0.15, 0.20, 0.25, 0.35, programmable
CCM	Default modulation mode
VCM, ACM, multiple streams, generic streams, null-packet deletion	Supported through L.3 baseband frames. The frames specify the transmission format and the user data. Baseband frames can be created with a custom mode-adaptation application or through DekTec's L3Mux utility. The resulting L.3 file can be played using the StreamXpress player or using a custom application via the DekTec DTAPI.
GSE-Lite HEM (High Efficiency Mode)	GSE-packets
Channel bonding	Not supported
FEATURES	
Input format	MPEG-2 Transport Stream L.3X baseband frames GSE-packets
Channel simulation	AWGN insertion with adjustable SNR
SOFTWARE SUPPORT	
L3Mux	Utility for creating L.3X baseband frame files
StreamXpress	Application to play Transport Stream files or L.3X baseband frame files, and modulate in DVB-S2X.
DTAPI SDK	SDK for creating custom applications that generate DVB-S2X directly.

6.13. DVB-T/H

Parameter / Feature	Value / Comment
STANDARD	EN 302 769-2
MODULATION PARAMETERS	
Bandwidth	5, 6, 7, 8 MHz
Constellation	QPSK, 16-QAM, 64-QAM
Code rate	1/2, 2/3, 3/4, 5/6, 7/8
FFT mode	2k, 4k, 8k
Interleaving	Native, in-depth
Guard interval	1/32, 1/16, 1/8, 1/4
TPS format	DVB-T, DVB-H
FEATURES	
Input format	MPEG-2 Transport Stream
Channel simulation	AWGN insertion with adjustable SNR, multipath fading, Rayleigh channels and Doppler.
SOFTWARE SUPPORT	
<i>StreamXpress</i>	Application to play Transport Stream files and modulate in DVB-T.
DTAPI SDK	SDK for creating custom applications that generate DVB-T directly.

6.14. DVB-T2

Parameter / Feature	Value / Comment
STANDARD	EN 302 755 v1.1.1, v1.2.1, v1.3.1
MODULATION PARAMETERS	
Bandwidth	1.7, 5, 6, 7, 8, 10 MHz
T2 version	1.1.1, 1.2.1, 1.3.1
T2 profile	Base, lite, base + lite
Number of PLPs	Single-PLP: 1 Multi-PLP: up to 255
PLP payload	Transport stream (TS), Generic Stream Encapsulation (GSE)
PAPR reduction	None, ACE, TR, ACE+TR
Transmitter signature	Through auxiliary-streams or FEFs
Other DVB-T2-parameters	All DVB-T2 defined parameters
FEATURES	
Input format	MPEG-2 Transport Stream GSE packets
Channel simulation	T2 Modulator Interface (T2-MI) AWGN insertion with adjustable SNR, multipath fading, Rayleigh channels and Doppler. MISO simulator, generating both MISO transmitter signals
SOFTWARE SUPPORT	
<i>T2Xpress</i>	For playing and modulating single-PLP and multi-PLP DVB-T2 streams with full control over the entire DVB-T2 parameter set
<i>StreamXpress</i>	Application to play Transport Stream files or T2-MI files and modulate in DVB-T2.
DTAPI SDK	SDK for creating custom applications that generate DVB-T2 directly. The DTAPI supports "Multi-PLP Extensions" to easily create multi-PLP applications.

6.15. I/Q Samples

Parameter / Feature	Value / Comment
STANDARD	DekTec proprietary
MODULATION PARAMETERS	
Sample rate	0.1 .. 125Msps
Roll off	None, 0.05, 0.10, 0.15, 0.20, 0.25, 0.35, programmable
FEATURES	
Input format	I/Q samples as pairs of 16-bit signed integers in I, Q order
Channel simulation	AWGN insertion with adjustable SNR, multipath fading, Rayleigh channels and Doppler.
SOFTWARE SUPPORT	
<i>StreamXpress</i>	Application to play I/Q sample files and modulate.
DTAPI SDK	SDK for creating custom applications that play out I/Q samples.

6.16. ISDB-S

Parameter / Feature	Value / Comment
STANDARD	ARIB STD-B20
MODULATION PARAMETERS	
Symbol rate	0.088 .. 85MBd
Number of layers	1 when using transport stream input Up to 4 when using ISDB-S streams input
Modulation and code rate	BPSK 1/2, QPSK 1/2, QPSK 2/3, QPSK 3/4, QPSK 5/6, QPSK 7/8, 8PSK 2/3
Roll off	0.35, programmable
FEATURES	
Input format	ISDB-S stream: Transport stream with TMCC encoded in SYNC bytes
Channel simulation	AWGN insertion with adjustable SNR
Number of channels	Maximum one channel
SOFTWARE SUPPORT	
<i>IsdbsMux</i>	Utility for multiplexing one or more transport-stream files into an ISDB-S stream.
<i>StreamXpress</i>	Application to play Transport Stream files and modulate in ISDB-S.
DTAPI SDK	SDK for creating custom applications that generate ISDB-S directly.

6.17. ISDB-S3

Parameter / Feature	Value / Comment
STANDARD	ARIB STD-B44
MODULATION PARAMETERS	
Symbol rate	0.088 .. 85MBd (default 33.7561MBd)
Modulation	BPSK, QPSK, 8PSK, 16APSK, 32APSK
Code rate	1/3, 2/5, 1/2, 3/5, 2/3, 3/4, 7/9, 4/5, 5/6, 7/8, 9/10
Roll off	0.03
FEATURES	
Input format	Broadcast-TLV-stream packets: UDP-packets with TMCC information (5810-byte payload)
Channel simulation	AWGN insertion with adjustable SNR
Number of channels	Maximum one channel
SOFTWARE SUPPORT	
<i>IsdbS3Mux</i>	Utility for multiplexing one or more transport-stream and single-TLV-stream files into a broadcast-TLV-stream pcap file.
<i>DtPlay</i>	Application for play a broadcast TLV-stream pcap file and modulate in ISDB-S3.
DTAPI SDK	SDK for creating custom applications that generate ISDB-S3 directly.

6.18. ISDB-T/T_{SB}

Parameter / Feature	Value / Comment
STANDARD	ARIB STD-B31 and ARIB STD-B29
MODULATION PARAMETERS	
Bandwidth	5, 6, 7, 8 MHz
Number of segments	ISDB-T: 13 ISDB-T _{SB} : 1, 3
Constellation	DQPSK, QPSK, 16-QAM, 64-QAM
Code rate	1/2, 2/3, 3/4, 5/6, 7/8
FFT mode	Mode 1 (2k), mode 2 (4k), mode 3 (8k)
Guard interval	1/4, 1/8, 1/16, 1/32
Interleaving	0, 1, 2, 4, 8, 16
IIP PID	Selectable
Partial reception	On, off
Emergency broadcasting	On, off
FEATURES	
Input format	MPEG-2 Transport Stream 204-byte transport stream with TMCC encoded in the last 16 bytes of the 204-byte transport packets
Channel simulation	AWGN insertion with adjustable SNR, multipath fading, Rayleigh channels and Doppler.
SOFTWARE SUPPORT	
<i>StreamXpress</i>	Application to play a Transport Stream file and modulate in ISDB-T. For ISDB-T, StreamXpress includes a hierarchical multiplexer.
DTAPI SDK	SDK for creating custom applications that generate ISDB-T directly. Includes a hierarchical multiplexer API.

6.19. ISDB-Tmm

Parameter / Feature	Value / Comment
STANDARD	ARIB STD-B46
MODULATION PARAMETERS	
Channel raster bandwidth	6, 7, 8 MHz
Total bandwidth	Up to 14.5 MHz
Number of segments	Up to 33, with any combination of 13-, 3- and 1-segment signals
Constellation	DQPSK, QPSK, 16-QAM, 64-QAM
Code rate	1/2, 2/3, 3/4, 5/6, 7/8
FFT mode	Mode 1 (2k), mode 2 (4k), mode 3 (8k)
Guard interval	1/4, 1/8, 1/16, 1/32
Interleaving	0, 1, 2, 4, 8, 16
IIP PID	Selectable
Partial reception	On, off
Emergency broadcasting	On, off
FEATURES	
Input format	MPEG-2 Transport Stream 204-byte transport stream with TMCC encoded in the last 16 bytes of the 204-byte transport packets
Channel simulation	AWGN insertion with adjustable SNR, multipath fading, Rayleigh channels and Doppler.
SOFTWARE SUPPORT	
<i>TmmXpress</i>	Application to play and modulate an ISDB-Tmm signal with full control over the ISDB-Tmm/T _{SB} /T parameters.
DTAPI SDK	SDK for creating custom applications that generate ISDB-Tmm directly.

6.20. QAM-A (DVB-C)

Parameter / Feature	Value / Comment
STANDARD	ITU-T J.83 Annex A and EN 300 429
MODULATION PARAMETERS	
Constellation	16-QAM, 32-QAM, 64-QAM, 128-QAM, 256-QAM
Roll off	0.15, programmable
FEATURES	
Input format	MPEG-2 Transport Stream
Channel simulation	AWGN insertion with adjustable SNR, multipath fading, Rayleigh channels and Doppler.
SOFTWARE SUPPORT	
<i>StreamXpress</i>	Application to play Transport Stream files and modulate in DVB-C.
DTAPI SDK	SDK for creating custom applications that generate DVB-C directly.

6.21. QAM-B

Parameter / Feature	Value / Comment
STANDARD	ITU-T J.83 Annex B
MODULATION PARAMETERS	
Constellation	16-QAM, 256-QAM
Roll-off	0.18 (64-QAM), 0.12 (256-QAM), programmable
Interleaving	All ITU-T J.83.B defined interleaving modes
FEATURES	
Input format	MPEG-2 Transport Stream
Channel simulation	AWGN insertion with adjustable SNR, multipath fading, Rayleigh channels and Doppler.
SOFTWARE SUPPORT	
<i>StreamXpress</i>	Application to play Transport Stream files and modulate in QAM-B.
DTAPI SDK	SDK for creating custom applications that generate QAM-B directly.

6.22. QAM-C (ISDB-C)

Parameter / Feature	Value / Comment
STANDARD	ITU-T J.83 Annex C
MODULATION PARAMETERS	
Constellation	16-QAM, 32-QAM, 64-QAM, 128-QAM, 256-QAM
Roll off	0.13, programmable
FEATURES	
Input format	MPEG-2 Transport Stream
Channel simulation	AWGN insertion with adjustable SNR, multipath fading, Rayleigh channels and Doppler.
SOFTWARE SUPPORT	
<i>StreamXpress</i>	Application to play Transport Stream files and modulate in QAM-C.
DTAPI SDK	SDK for creating custom applications that generate QAM-C directly.

7. Performance Measurements

7.1. Phase Noise

The figures below show the phase noise of a CW signal generated by the DTA-2116, measured at different RF frequencies: 50, 500, 1000, 2000, and 3000MHz.

PHASE NOISE					
Settings		Residual Noise		Spot Noise [T1]	
Signal Freq:	50.000060 MHz	Evaluation from 1 kHz to 1 MHz		1 kHz	-123.49 dBc/Hz
Signal Level:	-10.29 dBm	Residual PM	16.715 m°	10 kHz	-129.22 dBc/Hz
Signal Freq Δ:	-36.29 Hz	Residual FM	109.962 Hz	100 kHz	-131.22 dBc/Hz
Signal Level Δ:	0 dBm	RMS Jitter	0.9286 ps	1 MHz	-138.97 dBc/Hz

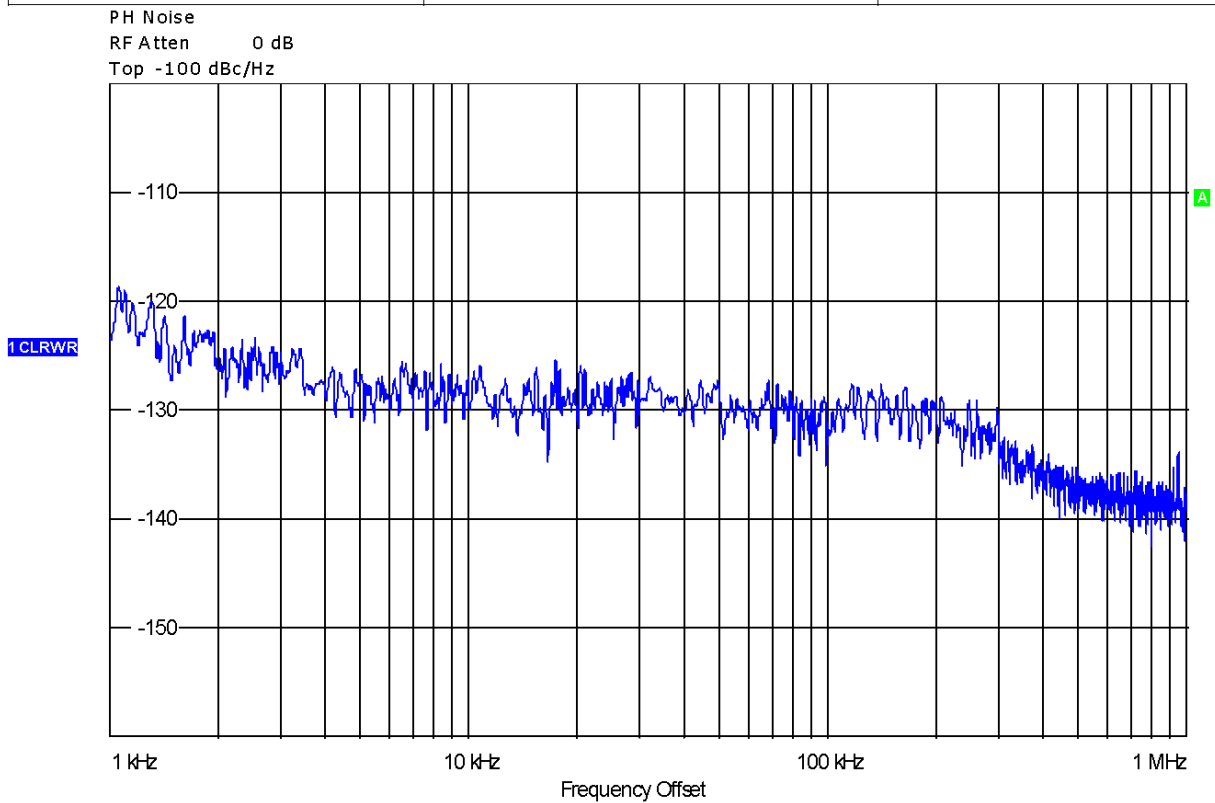

Measurement Aborted

Date: 16.JAN.2023 13:50:37

Figure 19. Phase noise @ 50MHz.

PHASE NOISE				
Settings		Residual Noise		Spot Noise [T1]
Signal Freq:	499.999504 MHz	Evaluation from 1 kHz to 1 MHz		1 kHz -101.54 dBc/Hz
Signal Level:	-10.16 dBm	Residual PM	23.81 m°	10 kHz -126.01 dBc/Hz
Signal FreqΔ:	0.24 Hz	Residual FM	110.263 Hz	100 kHz -127.94 dBc/Hz
Signal LevelΔ:	0 dBm	RMS Jitter	0.1323 ps	1 MHz -139.61 dBc/Hz

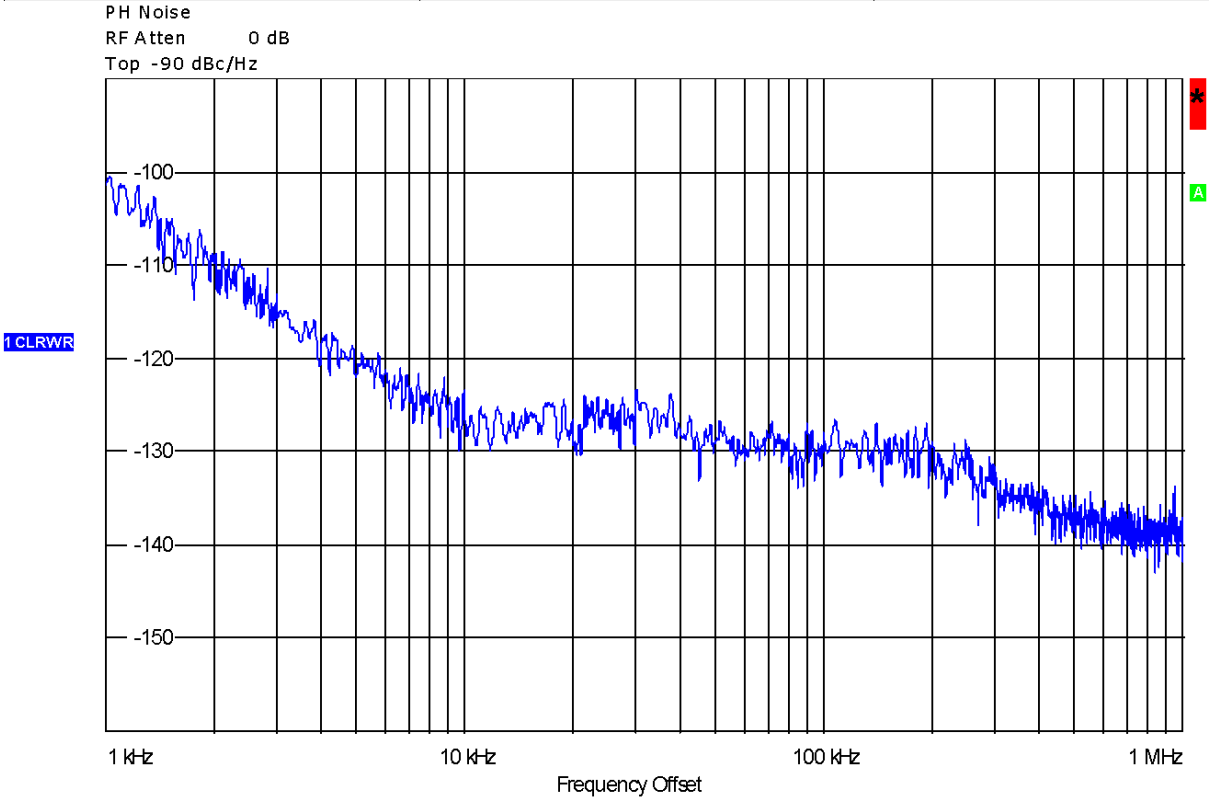

Measurement Aborted

Date: 16.JAN.2023 13:51:48

Figure 20. Phase noise @ 500MHz.

PHASE NOISE				
Settings		Residual Noise		Spot Noise [T1]
Signal Freq:	999.998986 MHz	Evaluation from 1 kHz to 1 MHz		1 kHz -95.66 dBc/Hz
Signal Level:	-10.41 dBm	Residual PM	38.326 m°	10 kHz -123.75 dBc/Hz
Signal FreqΔ:	0 Hz	Residual FM	109.481 Hz	100 kHz -126.66 dBc/Hz
Signal LevelΔ:	0 dBm	RMS Jitter	0.1065 ps	1 MHz -140.67 dBc/Hz

PH Noise
RF Atten 0 dB
Top -80 dBc/Hz

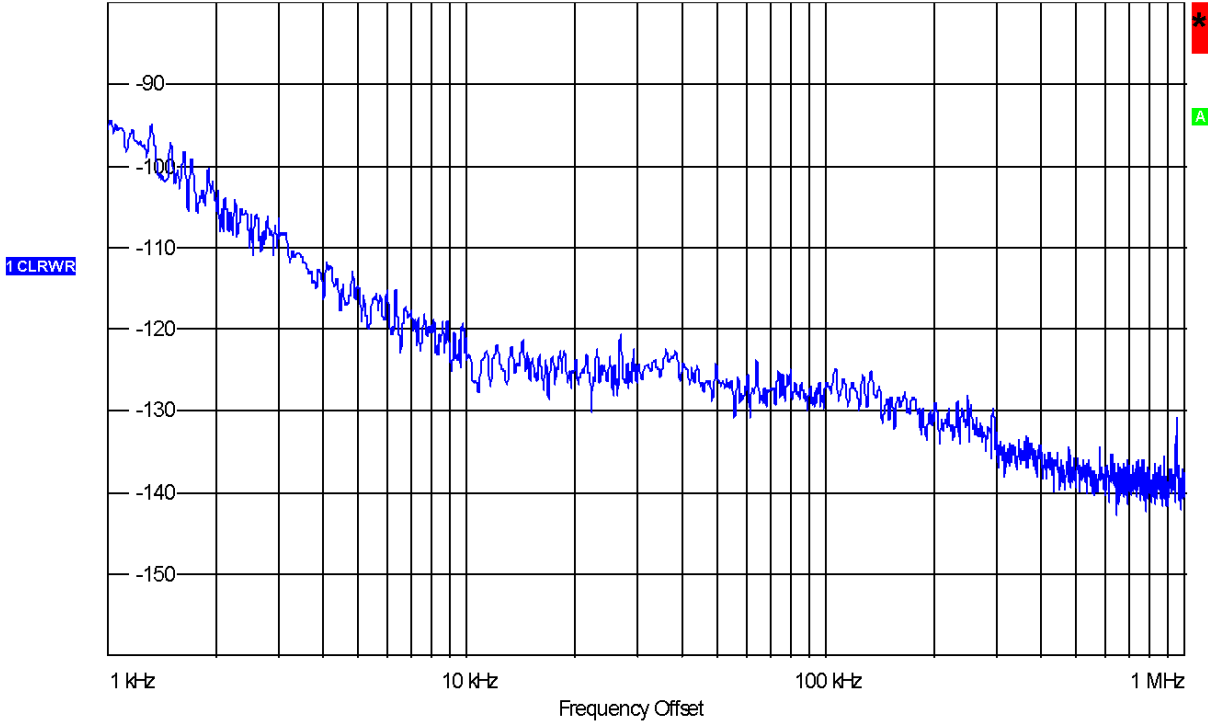

Measurement Aborted

Date: 16.JAN.2023 13:52:43

Figure 21. Phase noise @ 1000MHz.

PHASE NOISE				
Settings		Residual Noise		Spot Noise [T1]
Signal Freq:	1.999998 GHz	Evaluation from 1 kHz to 1 MHz		1 kHz -90.06 dBc/Hz
Signal Level:	-10.32 dBm	Residual PM	71.509 m°	10 kHz -117.63 dBc/Hz
Signal FreqΔ:	0.62 Hz	Residual FM	124.994 Hz	100 kHz -119.71 dBc/Hz
Signal LevelΔ:	0 dBm	RMS Jitter	0.0993 ps	1 MHz -139.67 dBc/Hz

PH Noise
RF Atten 0 dB
Top -70 dBc/Hz

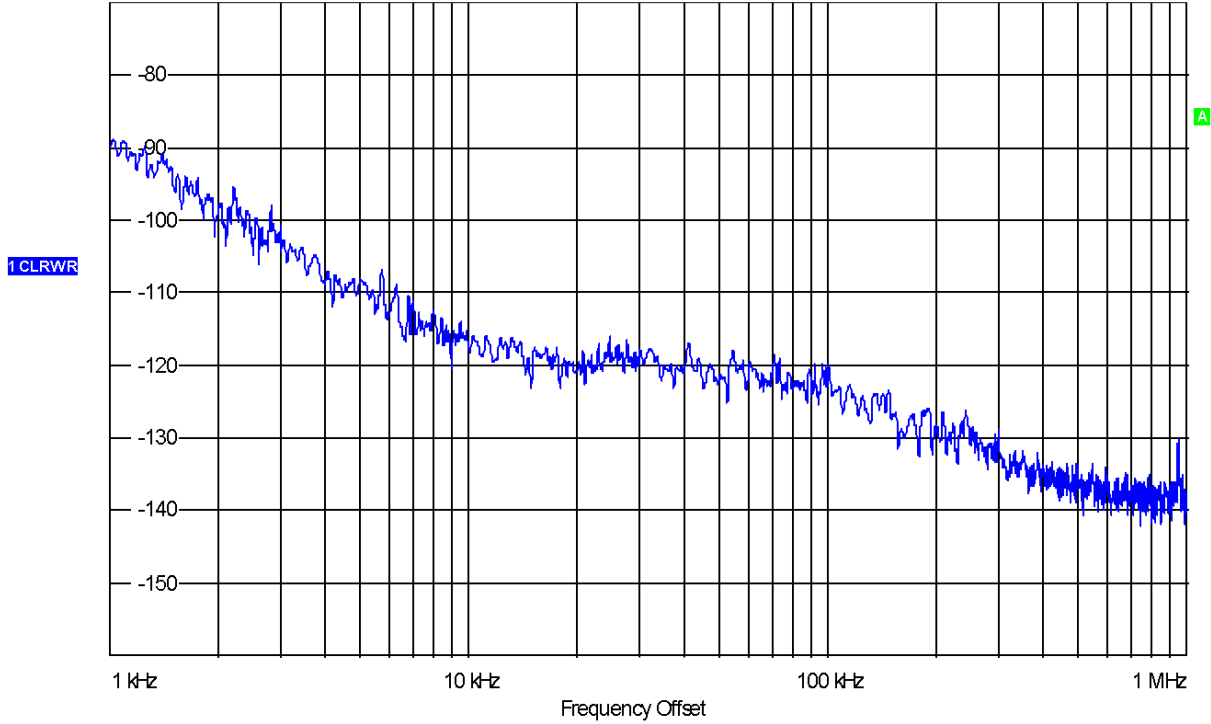

Measurement Aborted

Date: 16.JAN.2023 13:53:52

Figure 22. Phase noise @ 2000MHz.

PHASE NOISE					
Settings		Residual Noise		Spot Noise [T1]	
Signal Freq:	2.999997 GHz	Evaluation from 1 kHz to 1 MHz		1 kHz	-86.17 dBc/Hz
Signal Level:	-9.84 dBm	Residual PM	0.101 °	10 kHz	-115.33 dBc/Hz
Signal FreqΔ:	-64.9 Hz	Residual FM	119.463 Hz	100 kHz	-124.57 dBc/Hz
Signal LevelΔ:	-0.01 dBm	RMS Jitter	0.0934 ps	1 MHz	-139.85 dBc/Hz

PH Noise
RF Atten 0 dB
Top -70 dBc/Hz

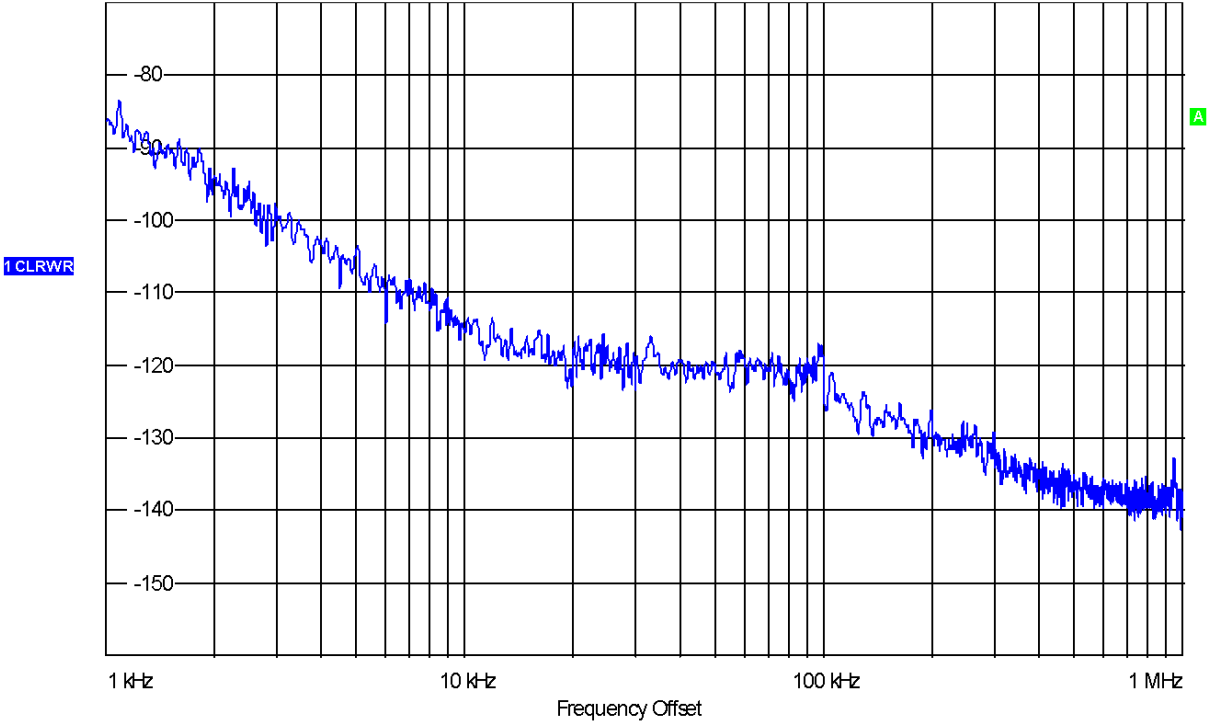

Measurement Aborted

Date: 16.JAN.2023 13:55:31

Figure 23. Phase noise @ 3000MHz.

7.2. Return Loss

The figures below show the return loss measured at the main- and monitor outputs of the DTA-2116.

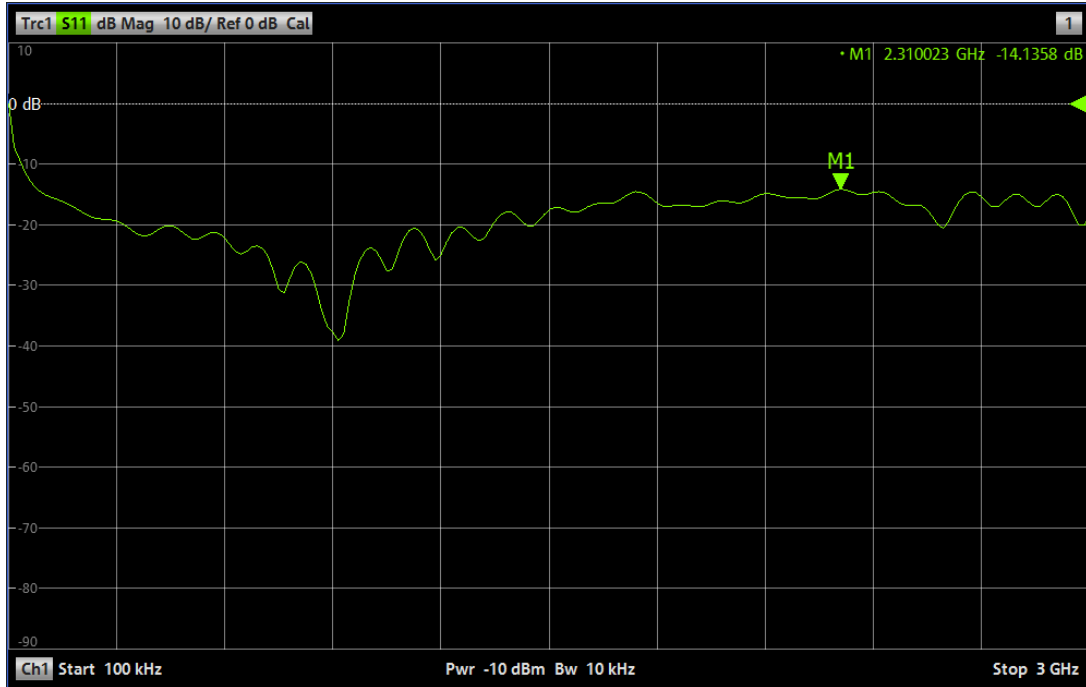

Figure 24. Return loss measurement of the main output (high output level).

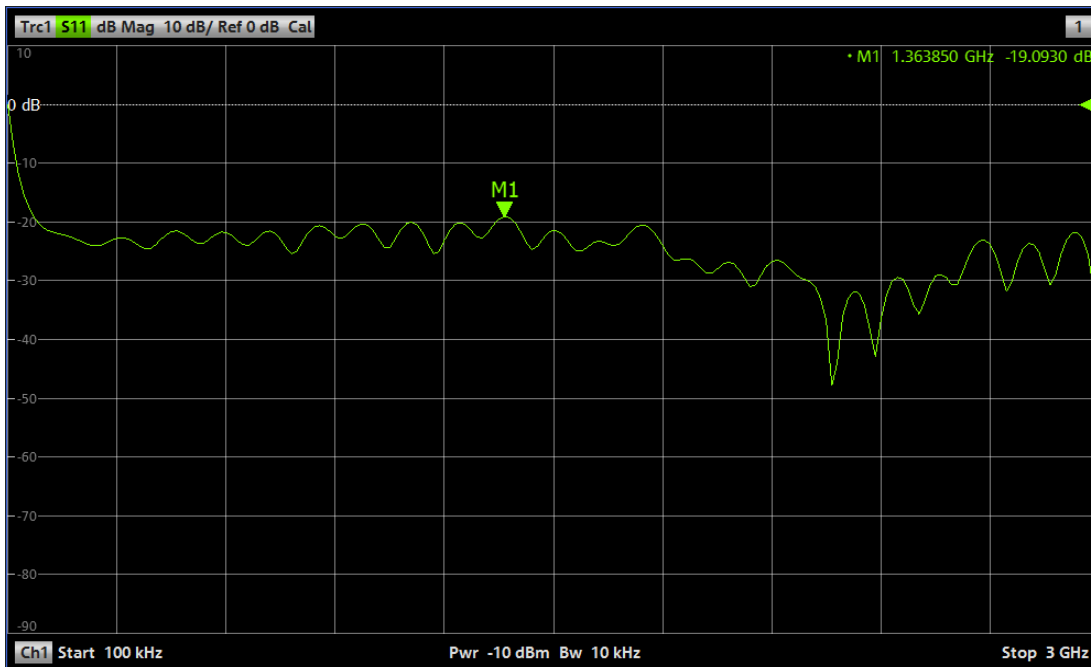

Figure 25. Return loss measurement of the main output (low output level).

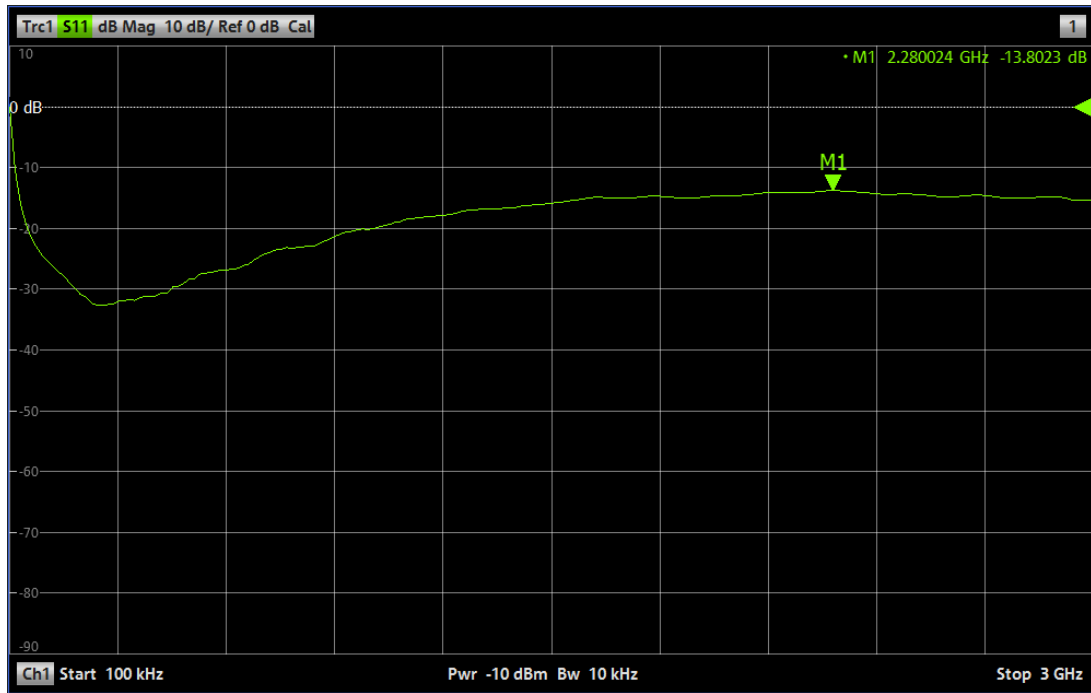

Figure 26. Return loss measurement of the monitor output.

7.3. Adjacent Channel Power

The graph below shows the power level of adjacent channels (ACP) at different RF frequencies when generating a DVB-C 256-QAM signal at 0dBm.

Remove this section? Or perform these measurements for the complete frequency band?

7.4. Shoulder Attenuation

The figures below show the shoulder attenuation, measured according to ETSI TR 101 290, using a DVB-T 8MHz signal at 1000MHz center frequency.

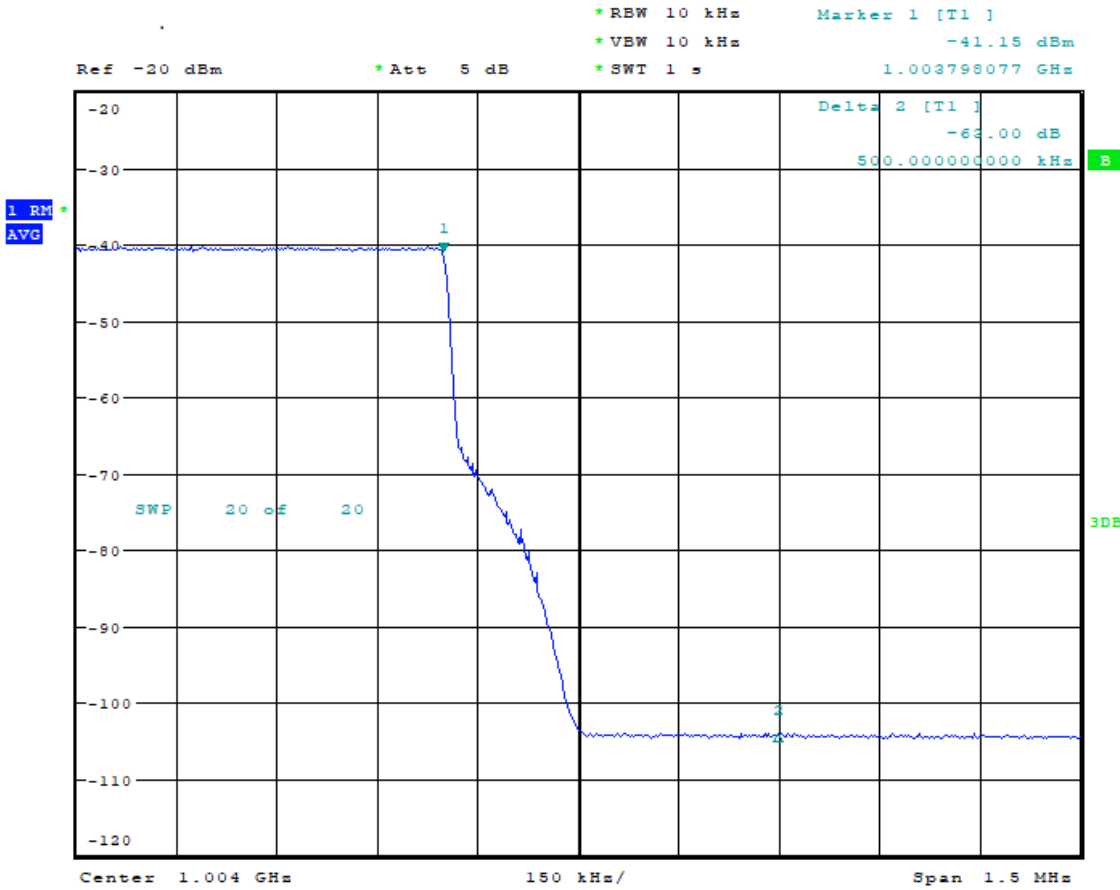

Date: 7.DEC.2022 11:41:15

Figure 27. Right shoulder attenuation.